

## 鑽石・氮化硼內孔磨棒 / Diamond & CBN Internal Points



■ 本系列產品主要使用於各種內孔研磨、治具研磨或小孔徑之精密研磨。

鑽石適用於研磨鎢鋼、陶瓷、藍寶石、玻璃...等。  
氮化硼適用於研磨熱處理硬化後之各種合金鋼材。

■ Diamond internal points are used for jig, internal grinding, and precision grinding of small holes in carbide, ceramics, sapphire, glass etc.  
CBN internal points are used similarly on tough, high carbon, high chrome harden steels.

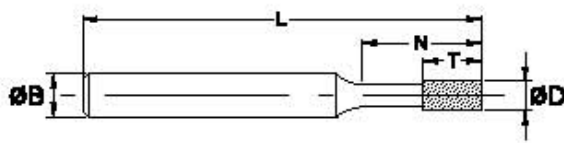

Type A

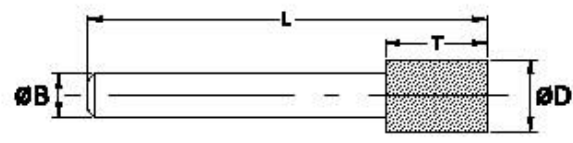

Type B

單位 / Unit : mm

編號 / Order no.		Type	$\phi D$	T	N	L	$\phi B$	粒度 Grit size
鑽石/Diamond	氮化硼/CBN							
ID-3003	IB-3003	A	0.3	2	4	35	3.0	#600
ID-3004	IB-3004	A	0.4	2	5	35	3.0	#400
ID-3005	IB-3005	A	0.5	2	5	35	3.0	#400
ID-3006	IB-3006	A	0.6	3	5	40	3.0	#200
ID-3007	IB-3007	A	0.7	3	8	40	3.0	#200
ID-3008	IB-3008	A	0.8	3	8	40	3.0	#200
ID-3009	IB-3009	A	0.9	4	8	40	3.0	#200
ID-3010	IB-3010	A	1.0	5	8	40	3.0	#200
ID-3015	IB-3015	A	1.5	5	8	45	3.0	#150
ID-3020	IB-3020	A	2.0	5	12	45	3.0	#150
ID-3025	IB-3025	A	2.5	5	15	45	3.0	#150
ID-3030	IB-3030	A	3.0	5	15	45	3.0	#150
ID-3040	IB-3040	B	4.0	5	-	50	3.0	#150
ID-3050	IB-3050	B	5.0	8	-	50	3.0	#150
ID-3060	IB-3060	B	6.0	8	-	50	3.0	#150
ID-6040	IB-6040	A	4.0	10	22	80	6.0	#100
ID-6050	IB-6050	A	5.0	10	22	80	6.0	#100
ID-6060	IB-6060	A	6.0	10	22	80	6.0	#100
ID-6070	IB-6070	B	7.0	10	-	80	6.0	#100
ID-6080	IB-6080	B	8.0	10	-	80	6.0	#100
ID-6090	IB-6090	B	9.0	10	-	80	6.0	#100
ID-6100	IB-6100	B	10	10	-	80	6.0	#100
ID-6120	IB-6120	B	12	10	-	80	6.0	#100
ID-6140	IB-6140	B	14	10	-	80	6.0	#100
ID-6160	IB-6160	B	16	10	-	80	6.0	#100
ID-6180	IB-6180	B	18	10	-	80	6.0	#100

■ 標準粒度外，其他粒度請指明訂購。 / Grit size in the above table is standard for that item, others are available upon request.

## 陶瓷法CBN內孔磨棒 / Vitrified CBN Internal Points



■ 陶瓷法 CBN 內孔磨棒主要使用於內孔研磨及治具研磨。氮化硼 (CBN) 適用於研磨高速鋼及各種熱處理硬化後之合金鋼材(濕磨)。

■ Vitrified CBN internal points are used for internal grinding and jig grinding of high speed steel and hardened alloy steel. (Wet Grinding)

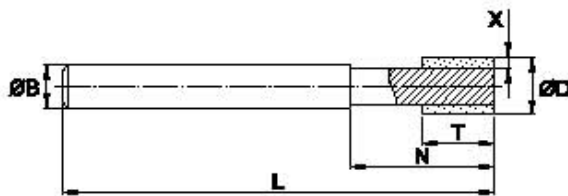

Type A

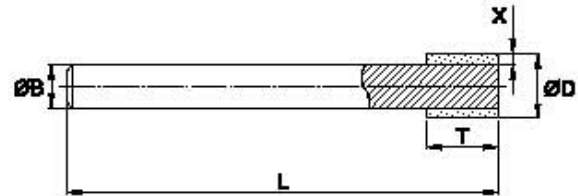

Type B

### 規格 / Specifications:

單位 / Unit : mm

編號 Order no.	Type	$\phi D$	T	X	N	L	$\phi B$	粒度 Grit size
VIB-3040	A	4.0	6	1.0	12	60	3	#200
VIB-3050	A	5.0	6	1.5	12	60	3	#200
VIB-3060	A	6.0	6	2.0	12	60	3	#200
VIB-3080	A	8.0	8	3.0	12	60	3	#200
VIB-6100	B	10.0	8	2.0	-	80	6	#200
VIB-6120	B	12.0	10	3.0	-	80	6	#200
VIB-8140	B	14.0	12	3.0	-	80	8	#200
VIB-6140	B	14.0	12	4.0	-	80	6	#200
VIB-8160	B	16.0	12	4.0	-	80	8	#200
VIB-6160	B	16.0	12	5.0	-	80	6	#200
VIB-8180	B	18.0	12	5.0	-	80	8	#200
VIB-6180	B	18.0	12	6.0	-	80	6	#200

■ 標準粒度外，其他粒度請指明訂購。

■ Grit size in the above table is standard for that item, others are available upon request.

## 樹脂法CBN內孔磨棒 / Resinoid CBN Internal Points



■ 樹脂法 CBN 內孔磨棒主要使用於內孔研磨及治具研磨。氮化硼 (CBN) 適用於研磨高速鋼及各種熱處理硬化後之合金鋼材。

■ Resinoid CBN internal points are used for internal grinding and jig grinding of high speed steel and hardened alloy steel.

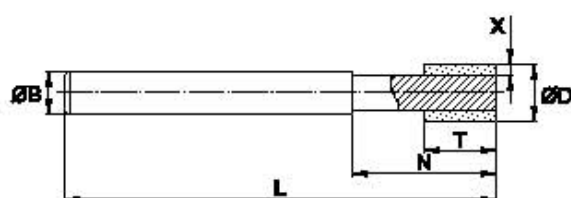

Type A

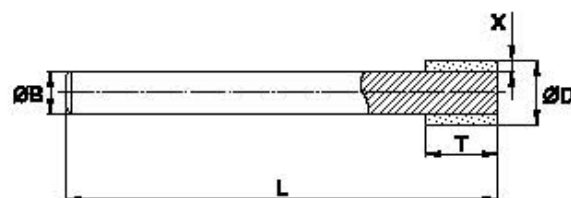

Type B

### 規格 / Specifications:

單位 / Unit : mm

編號 Order no.	Type	$\varnothing D$	T	X	N	L	$\varnothing B$	粒度 Grit size
RIB-3040	A	4.0	5	1.0	12	45	3	#200
RIB-3045	A	4.5	6	1.25	12	45	3	#200
RIB-3050	A	5.0	6	1.5	12	45	3	#200
RIB-6060	A	6.0	6	2.0	15	80	6	#150
RIB-6070	A	7.0	8	2.5	15	80	6	#150
RIB-6080	A	8.0	8	3.0	20	80	6	#150
RIB-6100	A	10.0	10	2.0	20	80	6	#150
RIB-6120	B	12.0	10	3.0	-	80	6	#150
RIB-6140	B	14.0	10	4.0	-	80	6	#150
RIB-6160	B	16.0	10	4.0	-	80	6	#150
RIB-6180	B	18.0	10	5.0	-	80	6	#150
RIB-6200	B	20.0	10	6.0	-	80	6	#150

■ 標準粒度外，其他粒度請指明訂購。





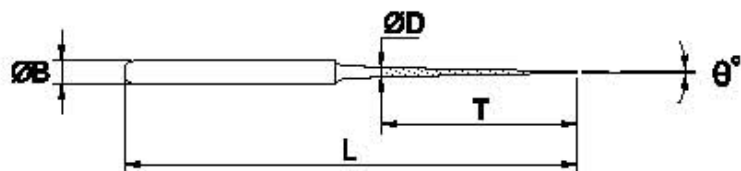





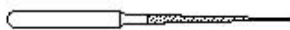

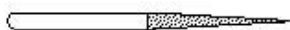
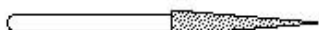
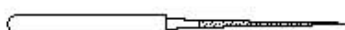
■ Grit size in the above table is standard for that item, others are available upon request.

# 鑽石磨棒 / Diamond Taper Points

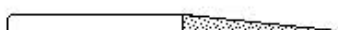

## 規格 / Specifications:

單位 / Unit : mm

	øD	T	θ°	øB	L	粒度 Grit size	編號 Order no.
	ø1.8	25	3.1	ø3.0	50	#140	18PL
	ø2.1	34	2.8	ø3.0	55	#140	20PXL
	ø3.0	25	6.4	ø3.0	50	#140	30PL
	ø4.8	26	9.6	ø3.0	55	#140	48PL
	ø1.5	26	2.3	ø3.0	60	#140	15PL
	ø2.0	48	1.9	ø3.0	73	#140	20PXL
	ø2.3	40	2.7	ø3.0	65	#140	23PXL
	ø2.5	45	2.6	ø3.0	70	#140	25PXL
	ø3.0	38	4.2	ø3.0	65	#140	30PXL
	ø6.0	33	10	ø6.0	60	#120	60P10
	ø6.0	28	12	ø6.0	60	#120	60P12
	ø6.0	23	14	ø6.0	60	#120	60P14
	ø6.0	21	16	ø6.0	60	#120	60P16
	ø6.0	17	20	ø6.0	60	#120	60P20
	ø10.0	19	30	ø6.0	60	#120	10P30

# 鑽石磨棒 / Diamond Mounted Points



## BC Series - $\phi 6.0$ mm shank

- 粒度：#40, #60, #100為標準粒度，訂購時請指明。  
例如：BC-65A, #40
- 柄徑： $\phi 6.0$ mm, 全長：60-65mm。
- Grit size available in #40, #60 and #100,  
When ordering, please specify.  
Ordering example: BC-65A, #40
- Shank diameter :  $\phi 6.0$ mm, Total length : 60-65mm.

單位 / Unit : mm

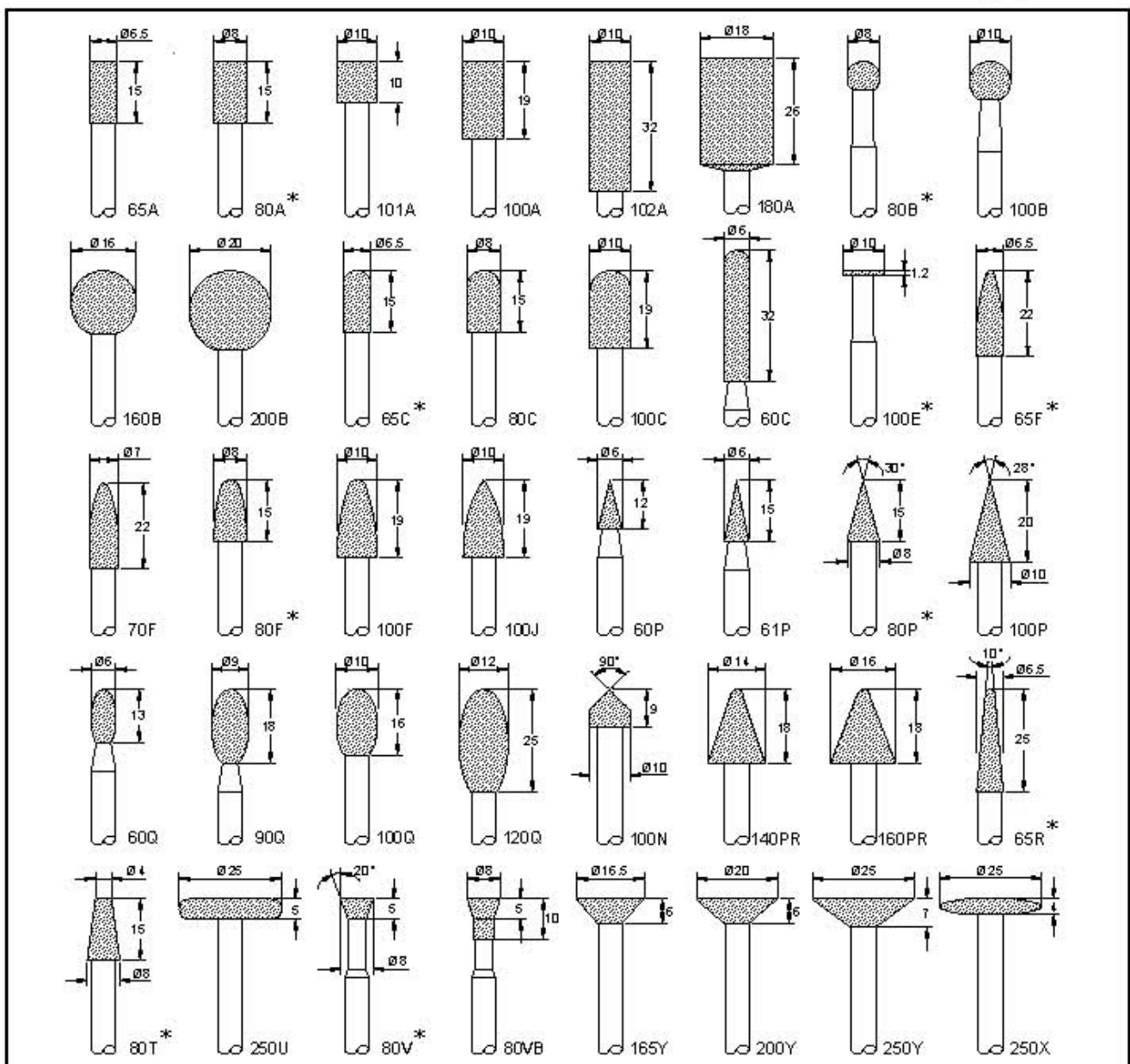

- BC-10 : 套裝10支組, 含標示 \* 號之磨棒各一支。訂購時請指明粒度, 例如：BC-10, #60
- BC-10 : 10 pcs. Assortment set, contains one each of above points, which denoted by \* .  
Ordering example : BC-10, #60

# 鑽石磨棒 / Diamond Mounted Points



BM Series -  $\phi$ 3.0mm shank

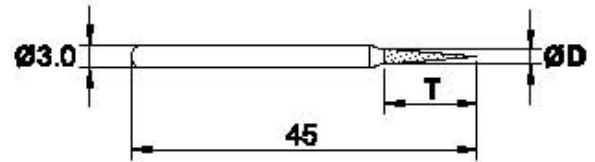

單位 / Unit : mm

Order no.	10A	15A	20A	25A	30A	35A	40A	50A	60A	10C	15C	20C	25C	30C
$\phi$ D	1	1.5	2	2.5	3	3.5	4	5	6	1	1.5	2	2.5	3
T	8	8	8	8	10	10	10	10	10	8	8	8	8	10
Grit size	#150	#150	#120	#120	#120	#120	#120	#100	#100	#150	#150	#120	#120	#120
Order no.	35C	40C	50C	60C	20T	30T	30V	13R	14R	15R	20R	30R	20P	30P
$\phi$ D	3.5	4	5	6	2	3	3	1.2	1.5	1.5	2	3	2	3
T	10	10	10	10	10	10	10	16	13	10	12	14	12	15
Grit size	#120	#120	#100	#100	#120	#120	#120	#150	#150	#150	#150	#120	#150	#150
Order no.	40P	50P	60P	20F	30F	40F	50F	60F	30J	40J	50J	60J	10B	15B
$\phi$ D	4	5	6	2	3	4	5	6	3	4	5	6	1	1.5
T	15	15	13	10	10	10	10	12	14	9	10	13	-	-
Grit size	#150	#150	#120	#120	#120	#120	#120	#120	#150	#150	#120	#120	#200	#150
Order no.	20B	25B	30B	40B	50B	60B	80B	30Q	40Q	50Q	60Q	20S	30S	40S
$\phi$ D	2	2.5	3	4	5	6	8	3	4	5	6	2	3	4
T	-	-	-	-	-	-	-	5	7	9	10	4	6	8
Grit size	#150	#120	#120	#120	#100	#100	#100	#120	#120	#100	#100	#150	#120	#120

- BMS-30 : 30支綜合組，含以上有標示\* 記號磨棒各1支。  
30 pieces assortment set, contains one each point which denoted by\*.
- BMS-20 : 20支綜合組，組裝內容如下 / 20 pieces set, contains one each of below :  
BM-10A, 15A, 20A, 25A, 30A, 35A, 15C, 20C, 25C, 30C,  
20P, 30P, 15R, 20R, 30R, 20B, 30B, 20F, 30F, 20T.
- The tools with  $\phi$ 1/8" shank or with CBN abrasive are available upon your request.

## 綜合組裝 / Assortment set



**30 BMS-30 : 30支組/30pcs.set**

組裝內容如下/Contains one each of below :

BM-10A, 15A, 20A, 25A, 30A, 35A, 40A,  
50A, 20B, 30B, 50B, 15C, 20C, 25C,  
30C, 35C, 40C, 50C, 20P, 30P, 15R,  
20R, 30R, 30S, 20F, 30F, 50F, 20T,  
30T, 30V. (各一支)。



**20 BMS-20 : 20支組/20pcs.set**

組裝內容如下/Contains one each of below :

BM-10A, 15A, 20A, 25A, 30A, 35A, 15C,  
20C, 25C, 30C, 20P, 30P, 15R, 20R,  
30R, 20B, 30B, 20F, 30F, 20T. (各一支)。

**BL 系列 :  $\phi 1/8$ " 柄**

所有BM系列磨棒均可以改成  $\phi 1/8$ " 柄,請指明訂購。

**30 BLS-30 : 30支組**

**20 BLS-20 : 20支組**

**BLS-30** 及 **BLS-20** 為標準庫存品之  $\phi 1/8$ " 柄磨棒,其內容物與 **BMS-30** 及 **BMS-20** 相同,只有柄徑不同。

**BL Series :  $\phi 1/8$ " Shank**

Shank measure  $\phi 1/8$ " in diameter is available upon request.

**BL** series are  $\phi 1/8$ " shank with all shapes and sizes the same as **BM** series.

**30 BLS-30 : 30pcs.set**

**20 BLS-20 : 20pcs.set**

**BLS-30** and **BLS-20** are standard assortment set stock available for  $\phi 1/8$ " shank , contains the same type of points as **BMS-30** and **BMS-20**.

# 鑽石磨棒 / Diamond Mounted Points



BH Series -  $\varnothing 2.34$  mm shank

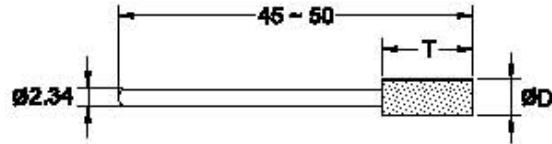

單位 / Unit : mm

Order no.	BH160E	BH60Q	BH60R	BH30A	BH25K	BH25J	BH25F	BH30V	BH15P	BH20B
$\varnothing D$	16	6.0	6.0	3.0	2.5	2.5	2.5	3.0	1.5	2.0
T	0.5	10	14	15	10	10	6	(45°)	10	-
Grit size	#200	#100	#100	#120	#150	#150	#120	#200	#200	#150

■ BHS-10 : 套裝10支組，含以上10種磨棒各1支。 / 10 pcs. set, contains one each of all above points.

Order no.	BH11A	BH14A	BH19A	BH24A	BH27A	BH32A	BH39A	BH49A	BH14R	BH24R
$\varnothing D$	1.1	1.4	1.9	2.4	2.7	3.2	3.9	4.9	1.4	2.4
T	7	7	7	7	7	7	10	10	10	13
Grit size	#150	#150	#120	#120	#120	#120	#120	#120	#150	#150

Order no.	BH20B	BH24B	BH30B	BH35B	BH39B	BH14C	BH19C	BH29C	BH39C	BH49C
$\varnothing D$	2.0	2.4	3.0	3.5	3.9	1.4	1.9	2.9	3.9	4.9
T	-	-	-	-	-	7	7	7	10	10
Grit size	#150	#120	#120	#120	#120	#150	#120	#120	#120	#120

Order no.	BH18P	BH24P	BH29P	BH42P	BH14T	BH19T	BH26T	BH30S	BH30Y	BH17J
$\varnothing D$	1.8	2.4	2.9	4.2	1.4	1.9	2.6	3.0	3.0	1.7
T	10	12	14	6	7	7	7	6	-	10
Grit size	#150	#150	#150	#150	#120	#120	#120	#120	#150	#150

■ BHS-30 : 套裝30支組，含以上30種磨棒各1支 / 30 pcs. set, contains one each of all above points.

■ BHS-20 : 套裝20支組，含以上有\*標示之磨棒各1支 / 20 pcs. set, contains one each of points which denoted by\*.



# 鑽石雕刻針 / Diamond Mounted Points

## BH Series - $\phi 2.34$ mm shank

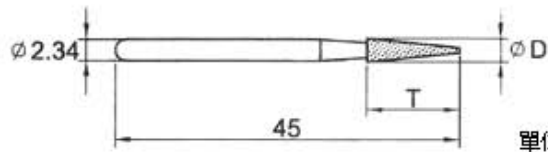

單位 / Unit : mm

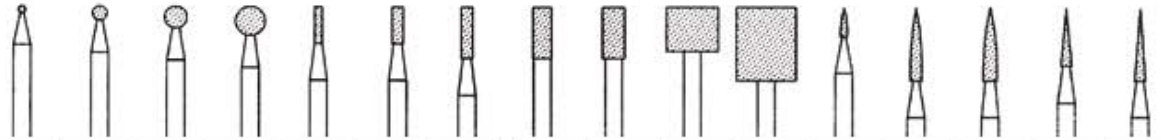

Order No.	D1	D2	D3	D4	A11	A12	A13	A21	A30	7A	8A	C3	C13	C23	TR	R
$\phi D$	1	2	3	4	1	1.5	1.5	2.5	3	7	8	0.9	1.5	2	1.5	1.5
T	-	-	-	-	5	5	7	7	7	6	10	4	10	10	8	10

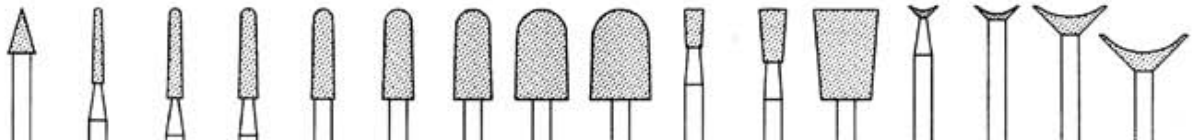

Order No.	KS	1LR	2R	2LR	3R	5R	6R	7R	8R	K6	K10	KA	12BA	14BA	16BA	19BA
$\phi D$	3.5	1.5	2	2.5	3	4	5	7	8	2	2.5	7	4	6	10	12
T	6	10	12	12	12	12	12	12	12	5	7	12	-	-	-	-

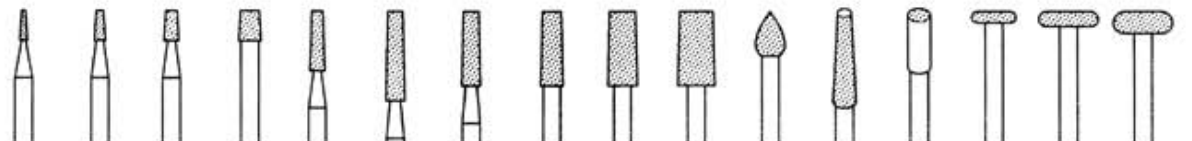

Order No.	T11	T12	T13	T30	1A	2A	2LA	3A	5A	6A	RZ	2LB	A14	Kr5	Kr8	Kr9
$\phi D$	1	1.5	2	3	2	2.5	2.5	3	4	5	4	2.5	2.5	6	8	8
T	4	4	4	4	8	12	10	10	10	10	6	12	7	1.5	2	3

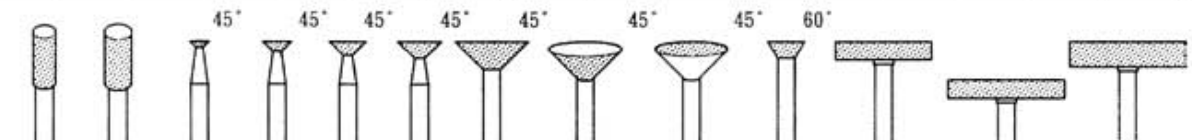

Order No.	A20	A31	10B	12B	13B	14B	16B	16BB	16BC	13nk	13mB	16mC	16mB
$\phi D$	2.5	3	2.7	4	5	6	10	10	10	5	13	16	16
T	7	7	-	-	-	-	-	-	-	-	2.5	2.5	3.5

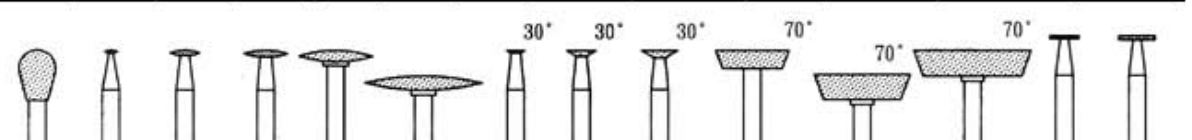

Order No.	RT	10X	17X	18X	19X	23X	10BN	12BN	13BN	10mA	13mA	16mA	K25	K30
$\phi D$	5	1.8	4	6	10	16	2.5	4	5	10	13	16	4	5
T	7	0.5	0.8	1	1.6	2	-	-	-	2.5	3.5	3.5	0.4	0.6

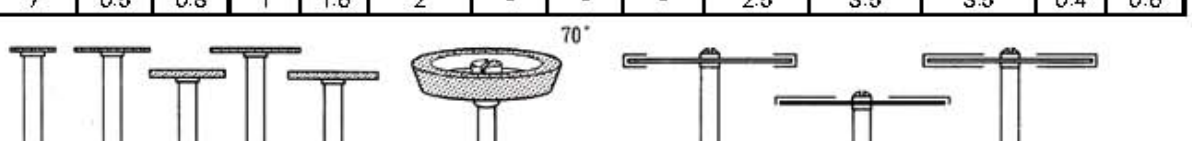

Order No.	K35	K45	K50	K55	K60	20mA	88D	88C	88A
$\phi D$	6	10	10	12	12	20	22	22	22
T	0.5	0.5	1	0.6	1	3.5	0.45	0.35	0.45

## 精密組鑽石銼刀 / Diamond Needle Files

### PF-10

- Total length : 140mm
- Tool shank :  $\phi 3.0$ mm
- Diamond coating length : 50mm



全長 : 140mm, 柄徑 :  $\phi 3.0$ mm, 鑽石長 : 50mm

形狀與尺寸 Shape & Size (mm)	編號 / Order no.		
	#120	#200	#400
1.  5.5 X 1.5	PF-101	PF-101F	PF-101V
2.  5 X 2	PF-102	PF-102F	PF-102V
3. $\phi 3$	PF-103	PF-103F	PF-103V
4.  2.5	PF-104	PF-104F	PF-104V
5.  3.5	PF-105	PF-105F	PF-105V
套裝5支組 / 5 pcs. set	PF-100	PF-100F	PF-100V

### PF-10L

- Total length : 140mm
- Tool shank :  $\phi 3.0$ mm
- Diamond coating length : 70mm



全長 : 140mm, 柄徑 :  $\phi 3.0$ mm, 鑽石長 : 70mm

形狀與尺寸 Shape & Size (mm)	編號 / Order no.		
	#120	#200	#400
1.  5.5 X 1.5	PF-101L	PF-101LF	PF-101LV
2.  5 X 2	PF-102L	PF-102LF	PF-102LV
3. $\phi 3$	PF-103L	PF-103LF	PF-103LV
4.  2.5	PF-104L	PF-104LF	PF-104LV
5.  3.5	PF-105L	PF-105LF	PF-105LV
6.  5.4 X 1.5	PF-106L	PF-106LF	PF-106LV
7.  1.7 X 6	PF-107L	PF-107LF	PF-107LV
8.  6 X 2	PF-108L	PF-108LF	PF-108LV
9.  5 X 2	PF-109L	PF-109LF	PF-109LV
10.  6 X 1.5	PF-110L	PF-110LF	PF-110LV
套裝10支組 / 10 pcs. set	PF-100L	PF-100LF	PF-100LV

### PF-70 Thin flat type

This thin flat type files with 0.5 ~ 1.0mm thickness, it is suitable for filing some narrow gap.

- Total length : 140mm, Tool shank :  $\phi 3.0$ mm
- Diamond coating length : 40 ~ 50mm



### PF-70 超薄平銼

此系列薄銼適用於窄縫加工。

全長 : 140mm, 柄徑 :  $\phi 3.0$ mm, 鑽石長 : 40 ~ 50mm

形狀與尺寸 Shape & Size (mm)	編號 / Order no.		
	#150	#200	#400
1.  5.5 X 0.5	PF-705	PF-705F	PF-705V
2.  5.5 X 0.8	PF-708	PF-708F	PF-708V
3.  5.5 X 1.0	PF-710	PF-710F	PF-710V

## 精密組鑽石銼刀 / Diamond Needle Files

### PFL-10

- Total length : 180mm
- Tool shank :  $\phi 3.0$ mm cover with PVC vinyl
- Diamond coating length : 25 ~ 50mm



全長 : 180mm 柄徑 :  $\phi 3.0$ mm, 套膠柄 鑽石長 : 25 ~ 50mm

形狀與尺寸 Shape & Size (mm)	編號 / Order no.		
	#200	#150	#400
1.  5.5 X 1.5	PFL-101	PFL-101J	PFL-101V
2.  5 X 2	PFL-102	PFL-102J	PFL-102V
3. $\phi 3$	PFL-103	PFL-103J	PFL-103V
4.  2.5	PFL-104	PFL-104J	PFL-104V
5.  3.5	PFL-105	PFL-105J	PFL-105V
6.  5.5 X 1	PFL-106	PFL-106J	PFL-106V
7.  5.5 X 0.5	PFL-705	PFL-705J	PFL-705V
8.  5.5 X 0.8	PFL-708	PFL-708J	PFL-708V
9. $\phi 2$	PFL-03	PFL-03J	PFL-03V
10.  5.5 X 1.5	PFL-01	PFL-01J	PFL-01V
套裝10支組 / 10 pcs. set	PFL-100	PFL-100J	PFL-100V

### PF-20

- Total length : 200mm
- Tool shank :  $\phi 4.0$ mm
- Diamond coating length : 70mm



全長 : 200mm 柄徑 :  $\phi 4.0$ mm 鑽石長 : 70mm

形狀與尺寸 Shape & Size (mm)	編號 / Order no.		
	#120	#200	#400
1.  8.5 X 1.6	PF-201	PF-201F	PF-201V
2.  7 X 2.5	PF-202	PF-202F	PF-202V
3. $\phi 4$	PF-203	PF-203F	PF-203V
4.  3.5	PF-204	PF-204F	PF-204V
5.  4.5	PF-205	PF-205F	PF-205V
套裝5支組 / 5 pcs. set	PF-200	PF-200F	PF-200V

### PF-30

- Total length : 180mm
- Tool shank :  $\phi 3.4$ mm
- Diamond coating length : 60mm



全長 : 180mm 柄徑 :  $\phi 3.4$ mm 鑽石長 : 60mm

形狀與尺寸 Shape & Size (mm)	編號 / Order no.		
	#120	#200	#400
1.  7.5 X 1.5	PF-301	PF-301F	PF-301V
2.  6 X 2.1	PF-302	PF-302F	PF-302V
3. $\phi 3.5$	PF-303	PF-303F	PF-303V
4.  3	PF-304	PF-304F	PF-304V
5.  4	PF-305	PF-305F	PF-305V
套裝5支組 / 5 pcs. set	PF-300	PF-300F	PF-300V

## 鑽石異形銼刀 / Diamond Bent Files

### BF-60

- Total length : 140mm
- Tool shank :  $\varnothing 3.0\text{mm}$
- Diamond coating length : 30mm



全長：140mm 柄徑： $\varnothing 3.0\text{mm}$  鑽石長：30mm

形狀與尺寸 Shape & Size (mm)	編號 / Order no.		
	#150	#200	#400
1.  6 X 1.3	BF-601	BF-601F	BF-601V
2.  5 X 2	BF-602	BF-602F	BF-602V
3. $\varnothing 3$	BF-603	BF-603F	BF-603V
4.  2.5	BF-604	BF-604F	BF-604V
5.  3.5	BF-605	BF-605F	BF-605V
套裝5支組 / 5 pcs. set	BF-600	BF-600F	BF-600V

### BF-80

- Total length : 155mm
- Tool shank : 3.0mm square shank
- Diamond coating length : 20 ~ 30mm (Double head)



全長：155mm 柄徑：3.0mm方柄 鑽石長：20 ~ 30mm (雙頭)

形狀與尺寸 Shape & Size (mm)	編號 / Order no.		
	#200	#150	#400
1.  3 X 2	BF-801	BF-801J	BF-801V
2. $\varnothing 2$	BF-802	BF-802J	BF-802V
3. $\varnothing 3$	BF-803	BF-803J	BF-803V
4. $\varnothing 3$	BF-804	BF-804J	BF-804V
5.  3	BF-805	BF-805J	BF-805V
6.  3	BF-806	BF-806J	BF-806V
套裝6支組 / 6 pcs. set	BF-800	BF-800F	BF-800V

### BF-90

- Total length : 140mm
- Tool shank :  $\varnothing 3.0\text{mm}$
- Diamond coating length : 20mm



全長：140mm 柄徑： $\varnothing 3.0\text{mm}$  鑽石長：20mm

形狀與尺寸 Shape & Size (mm)	編號 / Order no.		
	#150	#200	#400
1.  6 X 1.3	BF-901	BF-901F	BF-901V
2.  2.5	BF-902	BF-902F	BF-902V
3.  3.5 X 1.5	BF-903	BF-903F	BF-903V
4.  3.5	BF-904	BF-904F	BF-904V
5.  5 X 2	BF-905	BF-905F	BF-905V
6.  3.5 X 1.5	BF-906	BF-906F	BF-906V
7.  3.5 X 2	BF-907	BF-907F	BF-907V
8. $\varnothing 3$	BF-908	BF-908F	BF-908V
9.  5 X 1.5	BF-909	BF-909F	BF-909V
10. $\varnothing 2.3$	BF-910	BF-910F	BF-910V
套裝10支組 / 10 pcs. set	BF-900	BF-900F	BF-900V

# 鑽石平斜銼刀 / Diamond Tapered Hand Files



**PTF-100**



**CF-400**

## PTF-100

單位 / Unit : mm

	全長 Total length	鑽石長 Dia. length	形狀 Cross-section	粒度 Grit size	編號 Order no.
	130	30		#200	PTF-12F
				#400	PTF-12V
				#600	PTF-12X
	130	30		#200	PTF-14F
				#400	PTF-14V
				#600	PTF-14X
	130	30		#200	PTF-16F
				#400	PTF-16V
				#600	PTF-16X
	140	50		#600	PF-103X

10支裝 / 10 pcs. set in pvc pouch, contains one each of all above files

**PTF-100**

## CF-400

單位 / Unit : mm

	全長 Total length	鑽石長 Dia. length	形狀 Cross-section	粒度 Grit size	編號 Order no.
	180	40		#150	CF-402J
				#200	CF-402F
				#400	CF-402V
	180	50		#150	CF-404J
				#200	CF-404F
				#400	CF-404V
	180	50		#150	CF-406J
				#200	CF-406F
				#400	CF-406V
	180	50		#150	CF-408J
				#200	CF-408F
				#400	CF-408V







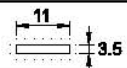

12支裝 / 12 pcs. set in pvc pouch, contains one each of all above files

**CF-400**

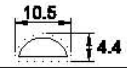
# 鐵工用鑽石銼刀 / Diamond Hand Files

## IF-50 鐵工用鑽石銼刀 / Diamond Hand Files

單位 / Unit : mm

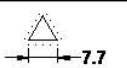
粒度/Grit size : #100	全長 Total length	鑽石長 Dia. length	形狀 Cross-section	編號 Order no.
	215	80		IF-501
	215	80		IF-502
	215	80		IF-503
	215	80		IF-504
	215	80		IF-505

## CF-50 鑽石平斜銼刀 / Diamond Hand Tapered Files

單位 / Unit : mm





粒度/Grit size : #150, #200	全長 Total length	鑽石長 Dia. length	形狀 Cross-section	編號 Order no.
	180	70		CF-501
	180	60		CF-502
	180	60		CF-503
	180	50		CF-504
	180	50		CF-505

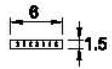

CF-500 木盒裝5支組 / (5pcs. set / wooden case)

## 金屬結合鑽石銼刀 / Sintered Diamond Files

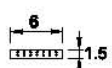
單位 / Unit : mm

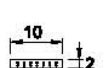
	全長 Total length	鑽石長 Dia. length	形狀 Cross-section	粒度 Grit size	編號 Order no.
	54	20		#200	MMF-615F
				#400	MMF-615V
				#600	MMF-615X
	72	20		#200	MDT-02F
				#400	MDT-02V
				#600	MDT-02X
	105	20		#200	MDT-03F
				#400	MDT-03V
				#600	MDT-03X

電動及氣動超音波研磨機專用 / Special design for pneumatic or ultrasonic lapping machine.

# 鑽石銼刀片 / Diamond Tip Files

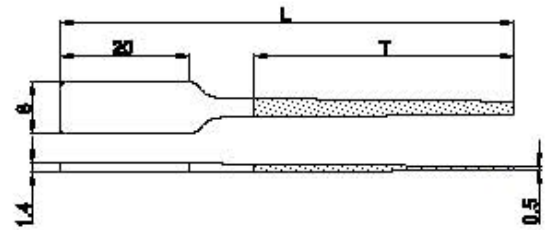

單位 / Unit : mm

L	T	形狀 Shape	粒度 Grit size	編號 Order no.
70	40		#150	FA-632J
			#200	★FA-632F
			#400	★FA-632V
			#600	★FA-632X
80	50		#150	★FA-643J
			#200	★FA-643F
			#400	★FA-643V
			#600	FA-643X
90	50		#150	★FA-666J
			#200	★FA-666F
			#400	FA-666V
90	50		#600	FA-666X
			#150	★FA-688J
			#200	★FA-688F
			#400	FA-688V
			#600	FA-688X
				XH-32

## FAS-600

10支綜合組裝包含上表有 ★ 標示之銼刀各一支。(銼刀夾柄另購)

10pcs. assortment set / pvc pouch, containing one each of file which denoted by asterisk. (Tool holder is optional.)

### 特點：

1. 節省材料。
2. 配合夾柄 (XH-32) 使用，手感更好。
3. 全新製程，切削力及壽命更好。
4. 可手持操作，亦可夾於機器上使用。
5. 銼刀形狀設計更合乎人體工學。
6. 可取代一般鑽石平斜銼刀。



### Features :

1. Less material usage.
2. The usage of holder (XH-32) makes it feel much better when operating.
3. Brand-new manufacturing process provides a better cutting ability and also prolongs the tool life.
4. Both suitable for hand-held and machine-mounted operations.
5. The designation is complied with the ergonomic.
6. Be able to replace the general diamond tapered hand files.

# 鑽石銼刀片 / Diamond Tip Files

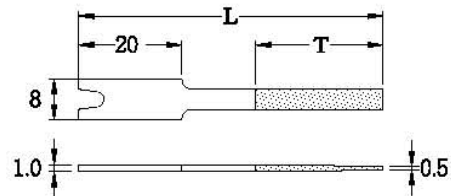

單位 / Unit : mm

L	T	形狀 Cross-section	粒度 Grit size	編號 Order no.
60	25		#150	★FA-426J
			#200	★FA-426F
			#400	FA-426V
60	25		#150	★FA-446J
			#200	★FA-446F
			#400	FA-446V
70	40		#150	★FA-667J
			#200	★FA-667F
			#400	FA-667V
70	40		#150	FA-887J
			#200	FA-887F
			#400	FA-887V
90	60		#150	★FA-889J
			#200	★FA-889F
			#400	FA-889V
70	40		#150	FA-107J
			#200	FA-107F
			#400	FA-107V
90	60		#150	★FA-109J
			#200	★FA-109F
			#400	FA-109V

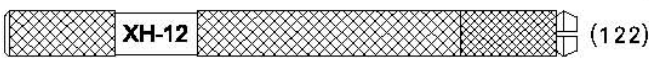

XH-12

10 10支組木盒裝，含夾柄1支及有★標示之銼刀各1支。  
10pcs. Set with tool holder / wooden case, containing one each of file which denoted by asterisk and one tool holder (XH-12).

FAS-100T

## 特點：

- (1) 富彈性，可彎曲研磨。
- (2) 厚度只有1mm，適合夾縫研磨。
- (3) 適合用於各種銼磨機及手持加工。

## Features :

- (1) With the maximum thickness of 1mm only, the files are suitable for narrow and deep gap processing. Contoured to make difficult-to-reach areas readily accessible.
- (2) They are tapered in thickness to make possible perfectly flat filing and flexible for bending while still maintaining their hardness.
- (3) Both suitable for hand-held and machine-mounted operations.

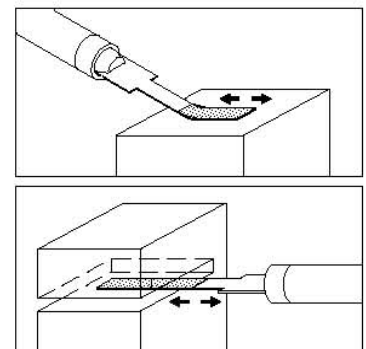



# 鑽石機械平斜銼刀 / Diamond Tapered Machine Files







**MTP-120**

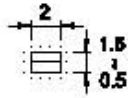

**MTF-100**

## MTP Series

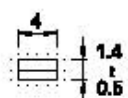
單位 / Unit : mm

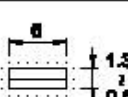





	全長 Total length	鑽石長 Dia. length	形狀 Cross-section	粒度 Grit size	編號 Order no.
	70	25		#150	MTP-12J
				#200	MTP-12F
				#300	MTP-12H
				#400	MTP-12V
	70	25		#150	MTP-14J
				#200	MTP-14F
				#300	MTP-14H
				#400	MTP-14V
	70	25		#150	MTP-16J
				#200	MTP-16F
				#300	MTP-16H
				#400	MTP-16V

12支裝 / 12 pcs. set in pvc pouch

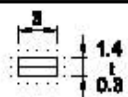
**MTP-120**

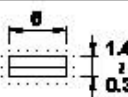
## MTF Series

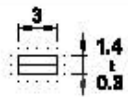
單位 / Unit : mm

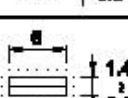
	全長 Total length	鑽石長 Dia. length	形狀 Cross-section	粒度 Grit size	編號 Order no.
	72	15		#200	MTF-13F
				#400	MTF-13V
				#600	MTF-13X
	72	15		#200	MTF-16F
				#400	MTF-16V
				#600	MTF-16X
	56	15		#200	MTF-23F
				#400	MTF-23V
				#600	MTF-23X
	56	15		#200	MTF-26F
				#400	MTF-26V
				#600	MTF-26X

12支裝 / 12 pcs. set in pvc pouch

**MTF-100**

## 鑽石機械銼刀 / Diamond Machine Files

### MPF-10

- Total length : 90mm
- Tool shank :  $\varnothing 3.0\text{mm}$
- Diamond coating length : 45mm



全長 : 90mm 柄徑 :  $\varnothing 3.0\text{mm}$  鑽石長 : 45mm

形狀 與 尺寸 Shape & Size (mm)	編號 / Order no.		
	#150	#200	#400
1.  4 X 1.2	<b>MPF-101</b>	MPF-101F	MPF-101V
2.  5 X 2	<b>MPF-102</b>	MPF-102F	MPF-102V
3. $\varnothing 3$	<b>MFF-103</b>	MPF-103F	MPF-103V
4.  2.5	<b>MPF-104</b>	MPF-104F	MPF-104V
5.  5 X 2	<b>MPF-109</b>	MPF-109F	MPF-109V
套裝5支組 / 5 pcs. set	<b>MPF-100</b>	MPF-100F	MPF-100V

### MBF-60

- Total length : 85mm
- Tool shank :  $\varnothing 3.0\text{mm}$
- Diamond coating length : 30mm



全長 : 85mm 柄徑 :  $\varnothing 3.0\text{mm}$  鑽石長 : 30mm

形狀 與 尺寸 Shape & Size (mm)	編號 / Order no.		
	#150	#200	#400
1.  5.5 X 1.2	<b>MBF-601</b>	MBF-601F	MBF-601V
2.  5 X 2	<b>MBF-602</b>	MBF-602F	MBF-602V
3. $\varnothing 3$	<b>MBF-603</b>	MBF-603F	MBF-603V
4.  2.5	<b>MBF-604</b>	MBF-604F	MBF-604V
5.  2.5	<b>MBF-605</b>	MBF-605F	MBF-605V
套裝5支組 / 5 pcs. set	<b>MBF-600</b>	MBF-600F	MBF-600V

### MBF-90

- Total length : 65mm
- Tool shank :  $\varnothing 3.0\text{mm}$
- Diamond coating length : 20 ~ 30mm



全長 : 65mm 柄徑 :  $\varnothing 3.0\text{mm}$  鑽石長 : 20 ~ 30mm

形狀 與 尺寸 Shape & Size (mm)	編號 / Order no.		
	#150	#200	#400
1.  5.8 X 1.2	<b>MBF-901</b>	MBF-901F	MBF-901V
2.  3.2 X 1.4	<b>MBF-902</b>	MBF-902F	MBF-902V
3.  5 X 2	<b>MBF-903</b>	MBF-903F	MBF-903V
4.  3.2 X 1.4	<b>MBF-904</b>	MBF-904F	MBF-904V
5. $\varnothing 3$	<b>MBF-905</b>	MBF-905F	MBF-905V
6. $\varnothing 3$	<b>MBF-906</b>	MBF-906F	MBF-906V
7.  2.5	<b>MBF-907</b>	MBF-907F	MBF-907V
8.  3.2 X 1.4	<b>MBF-908</b>	MBF-908F	MBF-908V
9.  3.2 X 1.4	<b>MBF-909</b>	MBF-909F	MBF-909V
10.  3.5 X 2	<b>MBF-910</b>	MBF-910F	MBF-910V
套裝10支組 / 10 pcs. set	<b>MBF-900</b>	MBF-900F	MBF-900V

## 鑽石油石 / Diamond Stones

■ 鑽石油石主要使用於各種刀具研磨後之刃部修磨，以延長刀具之壽命及提高加工物之表面光潔度。此外，亦適用於錐鋼、陶瓷及硬化後鋼料之表面研磨。

■ Diamond Stone is considered as final finish for cutting tools. It is used to refine a surface by removing scratch lines and other surface imperfections. Therefore prolong the tool's life and smooth a surface finish. Also apply to lap the tungsten, ceramics and hardened steels.

### 規格 / Specifications:

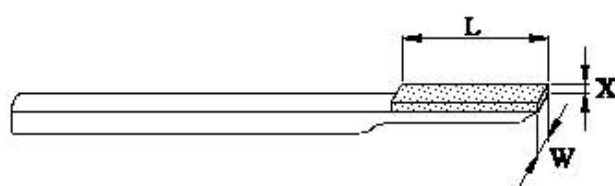

附柄型 / With shank

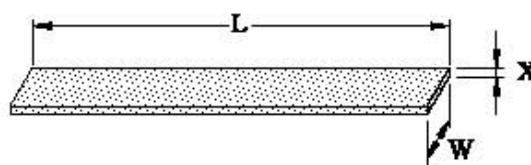

實心(無柄)型 / Solid (without shank)

單位 / Unit : mm

	尺寸/Dimensions W-(R)-X-L	柄部材質 Shank material	編號 Order no.
	10-2-40	塑膠柄 Plastic shank	RSH-01
	5-2-40	鐵柄 Steel shank	RSH-02
	5-2.5R-4-40	鐵柄 Steel shank	RSH-03
	10-2-30	鋁柄 Aluminum shank	RSH-04
	10-3-120	-	RS-04
	6-3-100	-	RS-05
	4-4-100	-	RS-06
	13-3-100	-	RS-07
	6-2-100	-	RS-08

Remark : 1. Grit size available : #200, #400, #600, #800, #1000, #1200, #1800, #2000, #3000, #5000.  
2. When ordering, please specify order no. & grit size.

說明 : 1. 標準粒度 : #200, #400, #600, #800, #1000, #1200, #1800, #2000, #3000, #5000。  
2. 訂購時，敬請指名產品編號與所需粒度。

## 鑽石纖維油石 / Ceramic Diamond Stones

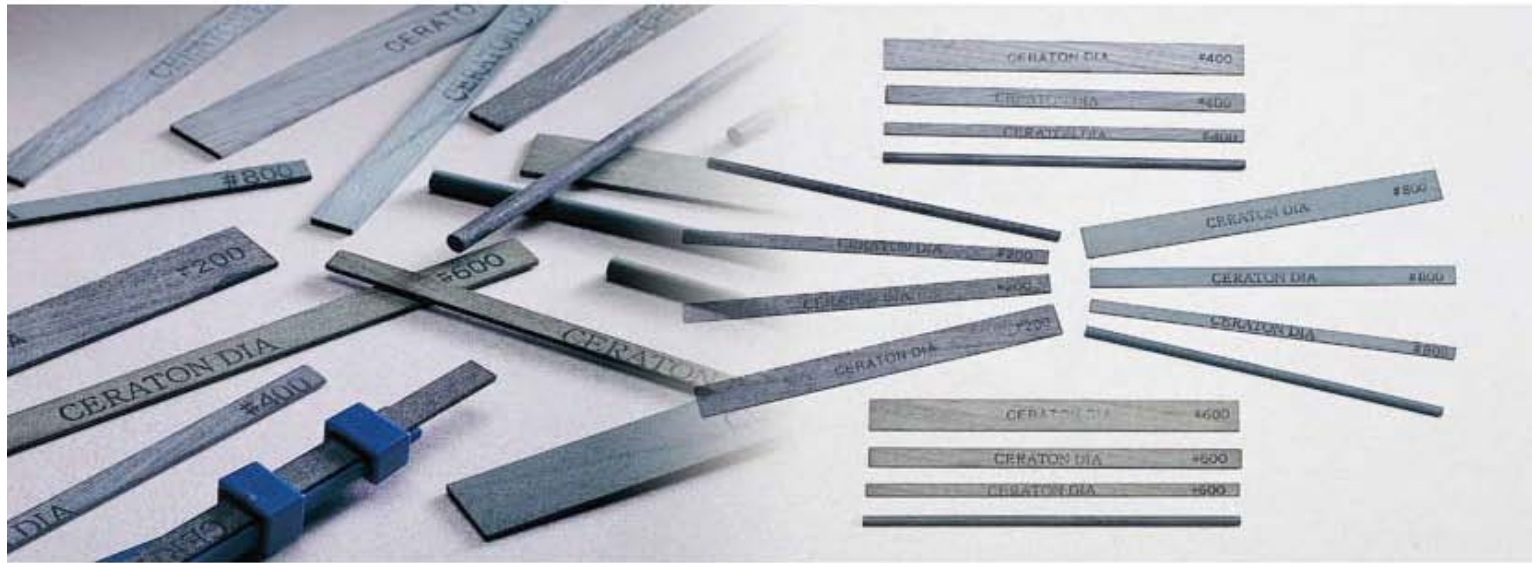

鑽石纖維油石是將鑽石磨料與陶瓷纖維以熱固型樹脂結合而成。由於鑽石優越的切削效果加上陶瓷纖維的高抗折強度，結合成一個完美的拋磨工具。鑽石磨料均勻地分布在陶瓷纖維上，使超級鑽石油石任何面均可研削且加工面很均勻，如此可以減少後續的加工作業時間。

特長：

1. 一般纖維油石只能用端面研削，而鑽石纖維油石任何面均有研磨效果。
2. 與樹脂鑽石油石比較，鑽石纖維油石有較佳的切削能力、不易塞目及不易折斷等優點。
3. 一些用一般纖維油石不易加工的材料，現在用鑽石纖維油石可以有效的切削。
4. 鑽石纖維油石適合使用於加工所有熱處理後的鋼材、碳化鎢、陶瓷及玻璃等。

**Ceramic diamond stones** are made of diamond abrasives and ceramic fibers bonded together with thermosetting resin. **Thanks diamond** for its outstanding cutting performance in combination with the superior tensile strength of ceramic fiber, generates ceramic diamond stone, a perfect lapping tool.

**Diamond particles** are sprayed on ceramic fibers for excellent uniform cutting action on every angle and therefore reduce after processing work.

Features :

1. The ordinary ceramic fiber stone is efficient only to lap its end side or edge, while the ceramic diamond stone works well with any sides.
2. In comparison to the resinous diamond stones, ceramic diamond stone is more aggressive in cutting rate, resist loading, and hardly broken.
3. Materials those are difficult to be ground by ordinary ceramic stone, now the ceramic diamond stone can provide a much better cut.
4. Ceramic diamond stone is ideal for lapping all kinds of harden steels, EDM surface, tungsten carbide, ceramics and glasses efficiently.

規格 / Specifications:

單位 / Unit : mm

	#200	#400	#600	#800
1 x 4 x 100	SDS-1042	SDS-1044	SDS-1046	SDS-1048
1 x 6 x 100	SDS-1062	SDS-1064	SDS-1066	SDS-1068
1 x 10 x 100	SDS-1102	SDS-1104	SDS-1106	SDS-1108
ø 3 x 100	SDG-302	SDG-304	SDG-306	SDG-308

其他粒度及尺寸亦可訂製。在某些特殊的用途，氮化硼纖維油石亦可訂製，敬請指名訂購。

In some special applications, ceramic CBN stones are also available, depend on your request.

# 鑽石膏 / Diamond Compounds 鑽石微粉 / Diamond Micron Powders

## 鑽石膏 Diamond Compounds



編號 Order no.	顆粒尺寸 Micron range ( $\mu\text{m}$ )	相等篩目 Mesh size (approx.)	標示顏色 Color code
PDR-280	0.5 (0-1)	#28,000	灰 / Grey
PDR-140	1 (0-2)	#14,000	白 / White
PDR-080	3 (2-4)	#8,000	黃 / Yellow
PDR-050	4.5 (3-6)	#5,000	淺棕 / Light brown
PDR-030	6 (4-8)	#3,000	橙 / Orange
PDR-020	8 (6-10)	#2,000	淺紫 / Lilac
PDR-018	9 (6-12)	#1,800	綠 / Green
PDR-015	13 (10-16)	#1,500	粉紅 / Pink
PDR-012	15 (10-20)	#1,200	藍 / Blue
PDR-010	17.5 (15-20)	#1,000	深綠 / Dark green
PDR-008	25 (20-30)	#800	咖啡 / Brown
PDR-006	35 (30-40)	#600	紅 / Red
PDR-004	50 (40-60)	#400	紫 / Purple
PDR-002	90 (80-100)	#200	黑 / Black

### 說明：

- 標準規格品為油溶性，若需水溶性鑽石膏，請指明訂購。
- 標準容量為5公克，其他容量：10公克或18公克裝，亦可指訂。
- 若需稀釋使用，本公司亦提供稀釋油。
- 高濃度系列亦可依需求而提供。

### Remark :

- Oil soluble is standard carries, other carries depend on your request.
- Containers : Plastic syringes, 5 grams per syringe. Others (10 or 18 grams) depend on your request.
- We also supply thinners for your special applications.
- High concentrations diamond compounds is also available, depend on your requirement.

## 鑽石微粉 Diamond Micron Powders



編號 / Order no.		顆粒尺寸 Micron range ( $\mu\text{m}$ )	相等篩目 Mesh size (approx.)
10 Carat	50 Carat		
DR-1280	DR-5280	0.5 (0-1)	#28,000
DR-1140	DR-5140	1 (0-2)	#14,000
DR-1080	DR-5080	3 (2-4)	#8,000
DR-1050	DR-5050	4.5 (3-6)	#5,000
DR-1030	DR-5030	6 (4-8)	#3,000
DR-1018	DR-5018	9 (6-12)	#1,800
DR-1012	DR-5012	15 (10-20)	#1,200
DR-1008	DR-5008	25 (20-30)	#800
DR-1006	DR-5006	35 (30-40)	#600
DR-1004	DR-5004	50 (40-60)	#400
DR-1002	DR-5002	90 (80-100)	#200

### 說明：

- 一品牌鑽石微粉乃經過精密設備嚴格篩選，粒度精確顆粒結晶形狀劃一。它適用於各種鋼模、超硬合金、陶瓷、寶石、半寶石等之精密拋光或鏡面拋光。
- 對於某些需求更精密或更均勻表面拋光之要求，請購時特別指明，本公司將提供更精密顆粒尺寸之微粉供選用。

### Remark :

- Our micron powders are precision graded from virgin material and especially designed for lapping and polishing operations. Particularly, those requiring the strictest dimensions accuracy and the finest surface finish.
- For works that require ultra high finish, we also supply powders with closer tolerance of the micron range upon your request.

# 棕刷及木條 / WOOD BOBS & BRUSH

## 木條 / Lapping Wood Stick

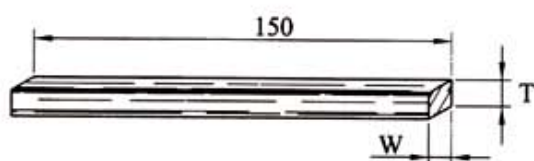

單位 / Unit : mm

Order.no.	AFW-05H	AFW-06H	AFW-07H	AFW-08H
T x W	6.4 x 6.4	3.2 x 6.4	3.2 x 9.5	6.5 x 12.7

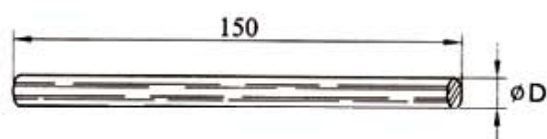

Order.no.	AFW-01H	AFW-02H	AFW-03H	AFW-04H
øD	ø3.2	ø4.7	ø6.4	ø9.5

## 木棒 / Wood Bobs

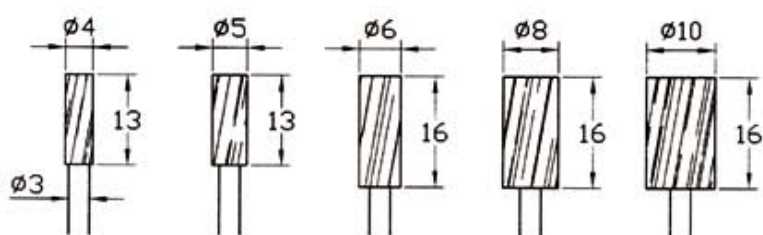

AFM-01

AFM-02

AFM-03

AFM-04

AFM-05

## 棕刷 / Brush

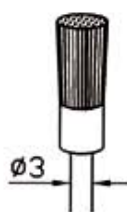

Order no.	AFB-01	AFB-02	AFB-03	AFB-04	AFB-05	AFB-06
øD	ø4.8	ø6.4	ø19	ø25.4	ø9/16"	ø1"

# 羊毛輪 / Felt Bobs



Felt Bobs -  $\phi$ 3.0mm Shank

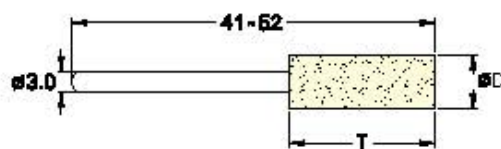

單位 / Unit : mm

Order no.	AB-0408A	AB-0509A	AB-0610A	AB-0810A	AB-1014A	AB-1220A	AB-1520A
$\phi D$	4	5	6	8	10	12	15
T	8	9	10	10	14	20	20
Order no.	AB-2020A	AB-0408C	AB-0509C	AB-0610C	AB-0810C	AB-1013C	AB-1214C
$\phi D$	20	4	5	6	8	10	12
T	20	8	9	10	10	13	14
Order no.	AB-1220C	AB-0410J	AB-0512J	AB-0616J	AB-0817J	AB-1014J	AB-1020J
$\phi D$	12	4	5	6	8	10	10
T	20	10	12	16	17	14	20
Order no.	AB-1220J	AB-1225J	AB-08B	AB-10B	AB-12B	AB-18B	AB-1014R
$\phi D$	12	12	8	10	12	18	10
T	20	25	-	-	-	-	14
Order no.	AB-1225R	AB-1218T	AB-1218H	AB-0610K	AB-0814K	AB-1014K	AB-1220K
$\phi D$	12	12	12	6	8	10	12
T	25	18	18	10	14	14	20

# 羊毛輪 / Felt Bobs

羊毛輪 / Felt Bobs -  $\phi 6.0\text{mm}$  Shank

單位 / Unit : mm

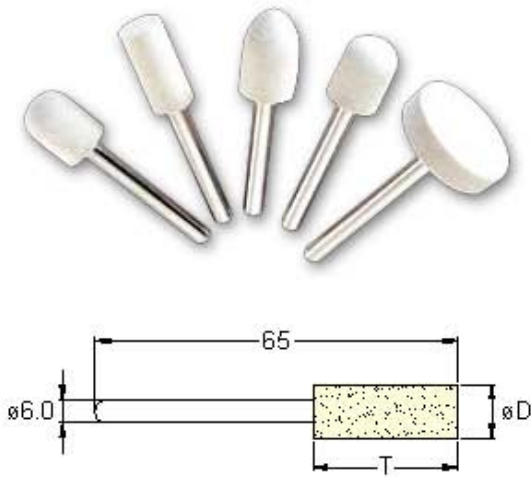

	Order No.	$\phi D$	T
	AC-1220A	12	20
	AC-1525A	15	25
	AC-2025A	20	25
	AC-2530A	25	30
	AC-1520C	15	20
	AC-2025C	20	25
	AC-2530C	25	30
	AC-3208E	32	8
	AC-4010E	40	9.6
	AC-1525K	15	25
	AC-2025K	20	25
	AC-2530K	25	30

其他羊毛製品 / Other Felt Products

單位 / Unit : mm

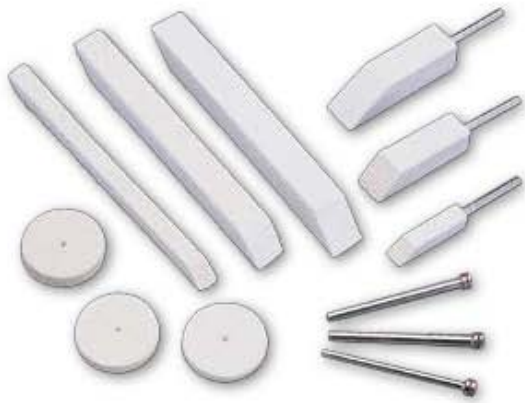

羊毛條 / Felt Stick

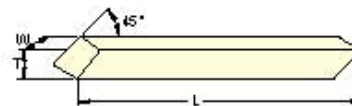

Order.no.	AB-S06	AB-S10
W x T x L	6 x 6 x 100 x 45°	10 x 10 x 100 x 45°

帶柄羊毛條 / Mounted Felt Stick

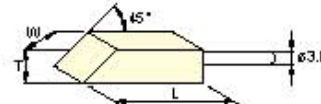

Order.no.	AB-R06	AB-R10	AB-R12
W x T x L	6 x 6 x 25	10 x 10 x 35	12 x 12 x 45

軸柄 / Mandrel For Felt Disc

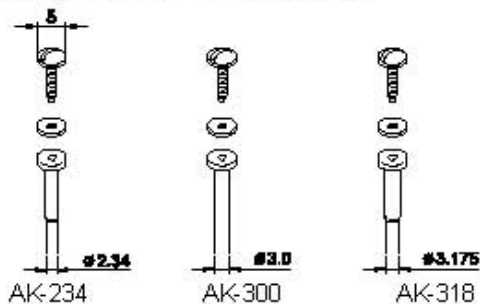

羊毛片 / Felt Disc

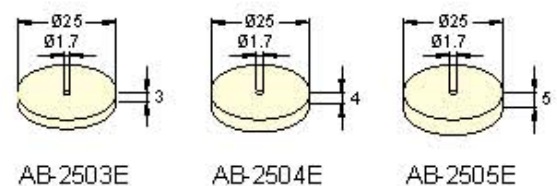



## 鑽石砂布 / Diamond Foils



- 鑽石砂布是以銅箔為基材，電著上一層鑽石粉，鑽石磨料佈滿整個銅箔表面。其特色為有較長之工具壽命，可以用刀片自由裁剪成所需尺寸及形狀，然後黏貼在各種工具上，成為您所需的自製工具。其優異的切削效果及多種粒度可供選擇，適合各種模具、鎢鋼、硬陶瓷、石材、玻璃等之研磨及拋光。另一種運用為將之黏在機器零件上增加耐磨耗及防止打滑。

Diamond powders are fully sprayed on the surface of copper foil, this features in longer tool life. The diamond foils can be cut to any shape & size easily, and stick on to your own tools, thus allowing for a whole range of tailored tools.

Aggressive cutting action and wide range of grit sizes produce fast cutting or polishing on hard steels of any hardness ^ tungsten carbides ^ stones ^ glass and hard ceramics...etc.

Other application of diamond foils is to stick on parts of machine to increase the wear resistant and avoid the sliding.

尺寸 Dimensions	粒度與編號 / Grit size & Order no.								
	#120	#150	#200	#300	#400	#600	#800	#1200	#1800
10 x 100mm	XF-1012	XF-1015	XF-1020	XF-1030	XF-1040	XF-1060	XF-1080	XF-1120	XF-1180
50 x 100mm	XF-2012	XF-2015	XF-2020	XF-2030	XF-2040	XF-2060	XF-2080	XF-2120	XF-2180
100 x 100mm	XF-3012	XF-3015	XF-3020	XF-3030	XF-3040	XF-3060	XF-3080	XF-3120	XF-3180
200 x 200mm	XF-4012	XF-4015	XF-3020	XF-4030	XF-4040	XF-4060	XF-4080	XF-4120	XF-4180

說明：標準品全部將砂布背膠，只要撕下保護層即可使用。若特殊用途可指定無背膠砂布，自行用其他方式將砂布固定於所需之工具或零件上。

Remark : All standard foils come with PSA backing, when using, please remove the backing paper.  
The foils without PSA backing are also available on demand. For special applications, the users may use his own method to stick the foil on to the tools or parts .

### 鑽石砂布、網狀鑽石布之運用例：

#### Application Example of Diamond Foils & Diamond Cloth:



## 鑽石布 / Diamond Cloth

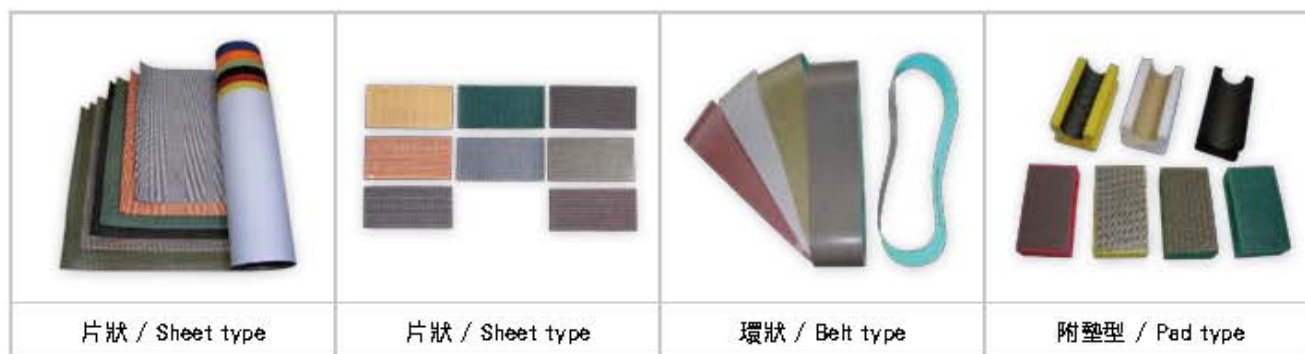

片狀 / Sheet type

片狀 / Sheet type

環狀 / Belt type

附墊型 / Pad type

The application of diamond power on a flexible cloth has allowed the development of a new generation of diamond tools ◦

This tools perform a more aggressive cutting action than any other abrasive tool, thanks to its flexibility and to the spacing between islands, the diamond cloth can be easily cut with scissors, thus allowing for a whole range of traditional abrasives only ◦

All diamond cloth products are color coded for easy identification of mesh and these series products can be in sheet, discs self-adhesive or velcro backing, or in belt type ◦

### Applications :

The applications of diamond cloth are:  
Wet grinding (lapping) harden steel of any hardness, tungsten carbide, hard ceramic coated steels, glass, hard ceramic, marble, granite and stone...etc, or for the lapping of mold and die.

鑽石布是將鑽石粉以電著法或樹脂結合法固著於帆布上,以前這種產品只有傳統砂布而已。

不同於傳統砂布的是,它有極佳的切削力,且在磨料與磨料間留有空隙作為研磨時逃屑用,因此研磨時不易塞目,且研磨後之工件表面非常均勻。

鑽石布可以用刀片或剪刀輕易地剪裁成所需要之尺寸,做成所需之工具。

鑽石布的粒度均以不同之顏色標示以資區別。它可為片狀亦可將之背膠作成環帶狀。

### 用途 :

鑽石布的運用很廣泛,例如:大理石,花崗石,等石材加工。任何硬度之硬質鋼材,碳化鎢,硬陶瓷披覆鋼材,硬陶瓷...等研磨,玻璃之倒角及磨邊,各種模具之研磨及拋光。

### 規格 / Specifications:

單位 / Unit : mm

粒度 Grid size	標示顏色 Color	結合劑 Bond Material	尺寸與編號 / Dimensions & Order No.			
			50 X 100	100 X 100	1,170 X 295	690 X 295
#60	綠色 / Green	鎳 / Ni bond	XZ-1006N	XZ-2006N	XZ-5006N	-
#120	黑色 / Black	鎳 / Ni bond	XZ-1012N	XZ-2012N	XZ-5012N	-
#200	紅色 / Red	鎳 / Ni bond	XZ-1020N	XZ-2020N	XZ-5020N	-
#400	黃色 / Yellow	鎳 / Ni bond	XZ-1040N	XZ-2040N	XZ-5040N	-
#600	白色 / White	鎳 / Ni bond	XZ-1060N	XZ-2060N	XZ-5060N	-
#1000	藍色 / Blue	鎳 / Ni bond	XZ-1100N	XZ-2100N	XZ-5100N	-
#500	白色 / White	樹脂 / Resin Bond	XZ-1050R	XZ-2050R	-	XZ-6050R
#1000	紫色 / Purple	樹脂 / Resin Bond	XZ-1100R	XZ-2100R	-	XZ-6100R
#3000	橙色 / Orange	樹脂 / Resin Bond	XZ-1300R	XZ-2300R	-	XZ-6300R

### 說明 / Remark :

- 標準尺寸 50 X 100mm 及 100 X 100mm 均有背膠,若不背膠請指明。
- 其他尺寸或形狀之鑽石布,請與我們業務人員聯絡。
- Standard 50 X 100mm and 100 X 100mm come with PSA backing, others come without PSA backing, please specify ◦
- Other size or type (shape), depend on your request ◦

# 鑽石修刀 / Diamond Dressing Tools

## 單石修刀 / Single Point Diamond Dressers

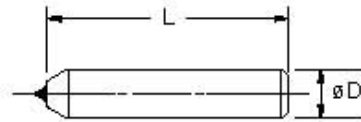

訂購時請說明編號及鐵柄尺寸或提供詳細圖面  
When ordering, please specify order no. & shank size or detail drawing.

鑽石番號 Dia. wt. code	大約重量(克拉) Approx. wt.(cts.)	編號 Order no.	適用砂輪 Grinding wheels size(mm)
#5	0.18	DS005	Ø150x25以下 or smaller
#10	0.20	DS010	
#15	0.25	DS015	
#20	0.35	DS020	Ø150-Ø300x25
#25	0.50	DS025	
#33	0.75	DS030	
#50	1.0	DS050	Ø300-Ø450x25-40
#75	1.5	DS075	Ø450-Ø600x50-100
#100	2.0	DS100	Ø600以上/or larger.

## 正確按裝及使用 / Installation and operation

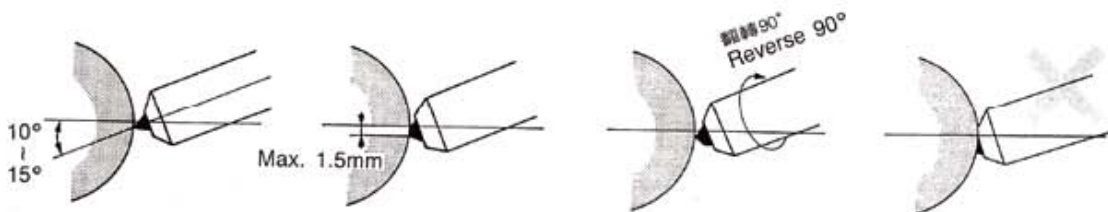

## 多石修刀 / Multi Point Diamond Dressers

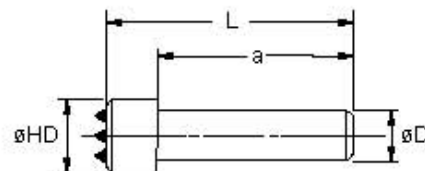

訂購時請說明編號及鐵柄尺寸或提供詳細圖面  
When ordering, please specify order no. & shank size or detail drawing.

總鑽石重量 Total stone weight	鑽石顆數 Nos. of stone	鑽石層數 Nos. of stone layer	編號 Order no.
1.0 Carat	3	1	DM03201
1.0 Carat	5	1	DM05101
1.0 Carat	6	1	DM06101
1.4 Carat	7	1	DM07101
0.6 Carat	3	1	DM03101

# 成型修刀 / Diamond Forming Dressers

## 成型修刀 / Chisel Type Diamond Dressers



■ 成型修刀用於砂輪之成形修整，或內、外弧之成形修整。  
For forming accurate radii and forms on grinding wheels.

鑽石角度 (V°)	鑽石端弧度 (R)	鑽石原料 Diamond material	編號 Order no.
55°	0.2 R	天然鑽石 Nature Diamond	DF0255
60°	0.5 R		DF0560
55°	0.2 R	人造鑽石 Synthetic Diamond	DF0255F
60°	0.5 R		DF0560F

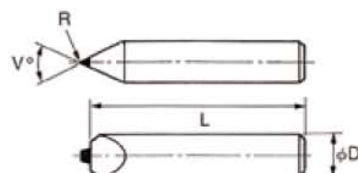

訂購時請說明編號及鐵柄尺寸或提供詳細圖面。

When ordering, please specify order no. & shank size or detail drawing.

## 圓錐修刀 / Coned Diamond Dressers



■ 圓錐修刀用於砂輪之成形修整，或內、外弧之成形修整。  
For forming accurate radii and forms on grinding wheels.

鑽石角度 (V°)	鑽石端弧度 (R)	鑽石原料 Diamond material	編號 Order no.
60°	0.02~0.03R	Ø1/8" x 1" L	DC600
60°	0.02~0.03R	Ø1/8" x 2" L	DC601
60°	0.02~0.03R	Ø1/4" x 2" L	DC602
60°	0.02~0.03R	Ø3/8" x 2" L	DC603
60°	0.02~0.03R	Ø10 x 50L(mm)	DC604

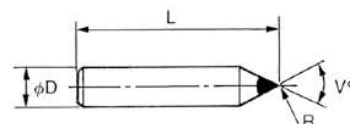

## CVD 成型修刀 / CVD Forming Dressers

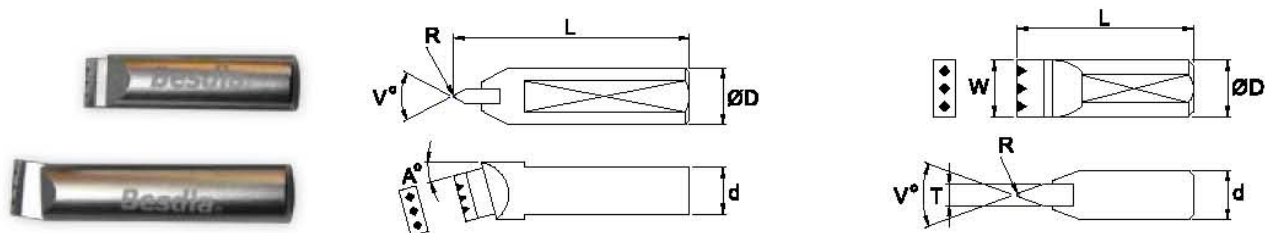

V°	A°	W	R	φD	d	L	鑽石顆數 Stone nos.	編號 Order no.
40	-	8	0.2	8	-	25	3	CVD-F0240-1
55	-	10	0.2	12	11	40	3	CVD-F0255-1
55	15	10	0.2	12	10	50	3	CVD-F02550-T1
55	6	10	0.2	12	11.5	50	3	CVD-F02550-T2

其他規格請提供詳細圖面訂購。

Other size, please offer detail drawing to order.

# 結合修刀 / Impregnated Diamond Dressers



鑽石齒塊尺寸 / The dimensions of diamond tips

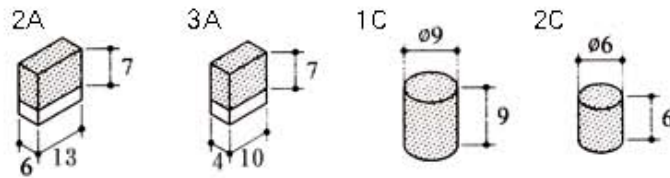

單位 / Unit : mm

編號 Order no.	鑽石齒塊 Diamond tips	粒度 Grit size	鐵柄形狀 Type of shank	鐵柄尺寸 Size of shank	適用範圍 Applications
DI-2AFC	2A	F		Ø12x100L	無心研磨,圓筒研磨,平面研磨 砂輪尺寸 Ø300x25 到 Ø500x63 For centerless,cylindrical,surface grinding. Wheel size : Ø300x25 to Ø500x63
DI-2AMC	2A	M		Ø12x50L	
DI-2ARC	2A	R		Ø11x30L	
DI-2AFD	2A	F		Ø12x50L Ø11x30L	
DI-2AMD	2A	M			
DI-2ARD	2A	R			
DI-1CFG	1C	F		Ø12x50L	一般用途之研磨 砂輪尺寸Ø300或以下 For general purpose grinding. Wheel size:Ø300and smaller.
DI-1CMG	1C	M		Ø11x30L	
DI-1CRG	1C	R			

粒度 / Grit size : F : 細目 / Fine M : 中目 / Medium R : 粗目 / Coarse

## 手持式鑽石修刀 / Hand Diamond Dressers



鑽石齒塊尺寸 / The dimensions of diamond tips

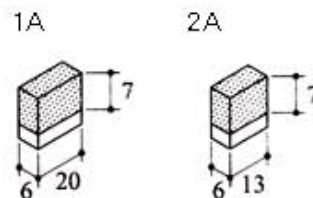

單位 / Unit : mm

形式 Form	編號 Order no.	鑽石齒塊 Diamond tips	粒度 Grit size
Type 01  總長 / Total length : 160mm	HD-01R HD-01F	 2A	R: 粗目/Coarse F: 細目/Fine
Type 02  總長 / Total length : 200 mm 方向 ① Direction ① 或 or 方向 ② Direction ②	HD-02R HD-02F	 1A	R: 粗目/Coarse F: 細目/Fine

## 電鑄鑽管 / Electroplated Diamond Core Drills



■ 此系列產品主要使用於FRP、超硬磁磚、人造花崗岩、花崗岩、拋光石英磚、瓷器、大理石、陶器、赤土陶器、玻璃、石墨、石材等材料之鑽孔。

■ **Diamond Plated Core Drills** are used for drilling FRP, hard tiles, artificial granite, granite, quartz, porcelain, marble, ceramic, terra cotta ceramic, glass, graphite, & stone.

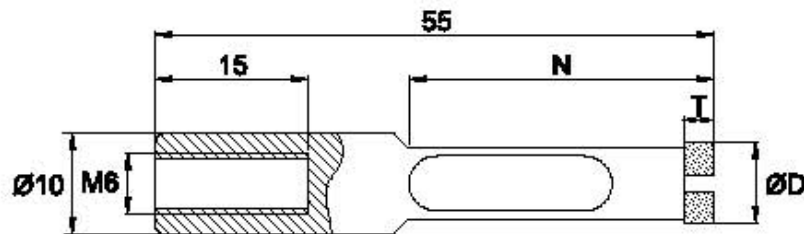

### 規格 / Specifications:

單位 / Unit : mm

編號 Order no.	øD		T	N	粒度 Grit size	備註 Note
	mm	inch				
ESD-032	3.2	1/8"	10	25	#60	Solid drills
ECD-050	5.0	3/16"	3	30	#60	Core Drills
ECD-065	6.5	1/4"	3	30	#60	Core Drills
ECD-080	8	5/16"	3	30	#60	Core Drills
ECD-100	10	3/8"	3	30	#60	Core Drills
ECD-130	13	1/2"	3	30	#60	Core Drills
ECD-160	16	5/8"	3	35	#60	Core Drills
ECD-191	19.05	3/4"	3	35	#60	Core Drills
ECD-254	25.4	1"	3	35	#60	Core Drills

■ 標準粒度外，其他粒度請指明訂購。

■ Grit size in the above table is standard for that item, others are available upon request.

## 電鑄鋸片 / Electroplated Diamond Cutters

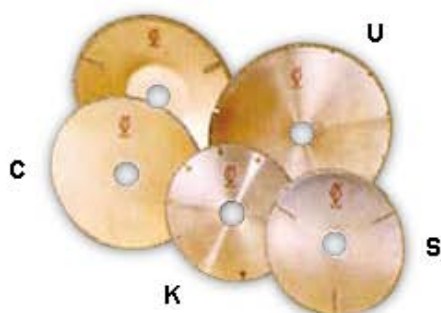

■ 此系列產品主要使用於大理石、磁磚、FRP、碳纖或石墨等之切割。

■ **Electroplated Diamond Cutters** are used for cutting marble, tile, FRP., carbon or graphics.

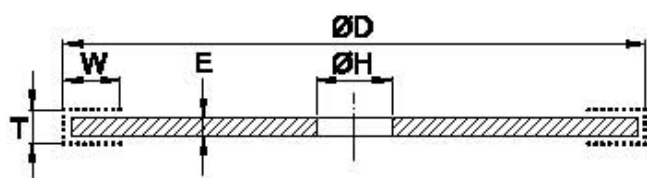

C: 連續式 / Continuous rim type

S: 幅條式 / Spoke type

U: U 溝式 / U-slot type

K: 水滴溝式 / Key hole slot type

### 規格 / Specifications:

單位 / Unit : mm

編號 Order no.	øD	E	T	W	型式 Type	øH	粒度 Grit size
SP-05008	50	0.8	1.8	2-3	C,S,U	Depend on your request 訂購時，敬請指明。	#40
SP-06308	63	0.8	1.8	2-3	C,S,U		#40
SP-10008	100	0.8	1.8	2-3	C,S,U		#40
SP-11508	115	0.8	1.8	2-3	C,S,U		#40
SP-11510K	115	1.0	2.0	2-3	K		#40
SP-12508	125	0.8	1.8	2-3	C,S,U		#40
SP-15008	150	0.8	1.8	2-3	C,S,U		#40
SP-15012	150	1.2	2.2	2-3	C,S,U		#40
SP-17512	175	1.2	2.2	2-3	C,S,U		#40
SP-20012	200	1.2	2.2	2-3	C,S,U		#40
SP-25012	250	1.2	2.2	2-3	C,S,U		#40
SP-30012	300	1.2	2.2	2-3	C,S,U		#40

■ 標準粒度外，其他粒度請指明訂購。

■ Grit size in the above table is standard for that item, others are available upon request.

# 鑽石與氮化硼砂輪 / Diamond & CBN Grinding Wheels

訂購砂輪時請指明下列事項：

1. 砂輪之形狀及各部尺寸：如1A1、14A1
2. 磨料種類：鑽石或氮化硼
3. 粒度：例如：#150
4. 集中度：例如：C-75
5. 結合劑：例如：樹脂結合劑或金屬結合劑
6. 冷卻方式：乾磨或濕磨
7. 數量及交期：
8. 轉速及加工條件：
9. 多數製造商都會在砂輪上標示以下資訊：

When ordering, please specify：

1. Shape & dimensions of wheel：Ex. 1A1, 14A1
2. Abrasive：Diamond or CBN
3. Grit size：Ex. #150
4. Concentration：Ex. C-75
5. Bond of wheel：Ex. Resin bond or Metal bond
6. Coolant：Dry or wet grinding
7. Quantity & Delivery date：
8. Spindle speed & grinding conditions：
9. Most of makers marked following information：

SDC 磨料種類 Abrasive	150 粒度 Grit Size	N 結合度 Grade	75 集中度 Concentration	R 結合劑 Bond	3.0 磨料層厚度 Rim thickness
D：天然鑽石 Natural diamond	#60 #80	J 軟 / Soft L N P R 硬 / Hard	25 50 75 100 125 150	R：樹脂結合 Resin bond M：金屬結合 Metal bond P：電鑄法 Electroplated V：陶瓷法 Vitrified	1.0mm 1.5mm 2.0mm 3.0mm 5.0mm 10.0mm . . .
SD：人造鑽石 Synthetic diamond	#100 #150				
SDC：人造金屬披覆鑽石 Synthetic metal coating diamond	#200 #270				
B：氮化硼 Cubic boron nitride (CBN)	#325 #400				
BC：金屬披覆氮化硼 CBN with metal coating	#600 .				

## 使用鑽石與氮化硼時機 / Choosing Diamond or CBN ?

### \* 鑽石

- 碳化鎢、半燒結碳化鎢工具及另件
- 陶瓷工具及另件
- 氧化鐵等之磁性材料
- 耐火材料及其製品
- 石材、寶石及半寶石、貝殼
- 玻璃、石英、瓷器
- 矽、鍍等電子另件
- 碳、石墨及其製品
- 磁磚、瀝青、混凝土、石棉
- 塑膠、加強塑料 (F.R.P.)
- 耐磨耗披覆材料

### \* Diamond

- Tungsten carbide, presintered carbide metal tools & construction units.
- Oxide ceramic materials.
- Ferrite, ceramic magnetic materials.
- Refractory products.
- Stones, gem & semi-precious stones, shell.
- Glass, porcelain, quartz.
- Graphite, carbon
- Tiles, asbestos, asphalt, concrete.
- Plastics, F.R.P.
- Wear resistant coatings.

### \* 氮化硼

- SK, SKS, SKH等切削工具及另件
- SKD, Stellite等耐磨工具鋼材
- SCM, SNCM, SCr, SUJ等構造用鋼
- SUS (不鏽鋼)等之耐蝕金屬
- SUH鈦合金等之耐熱金屬
- 鑄鐵

### \* CBN

- High alloy steels
- High speed tool steels
- Hot & cold working steels
- Tempering steels, Spring steel
- Ball bearing steel
- Cast iron



## 砂輪形狀及尺寸標示 / Shape & Dimensions of wheels

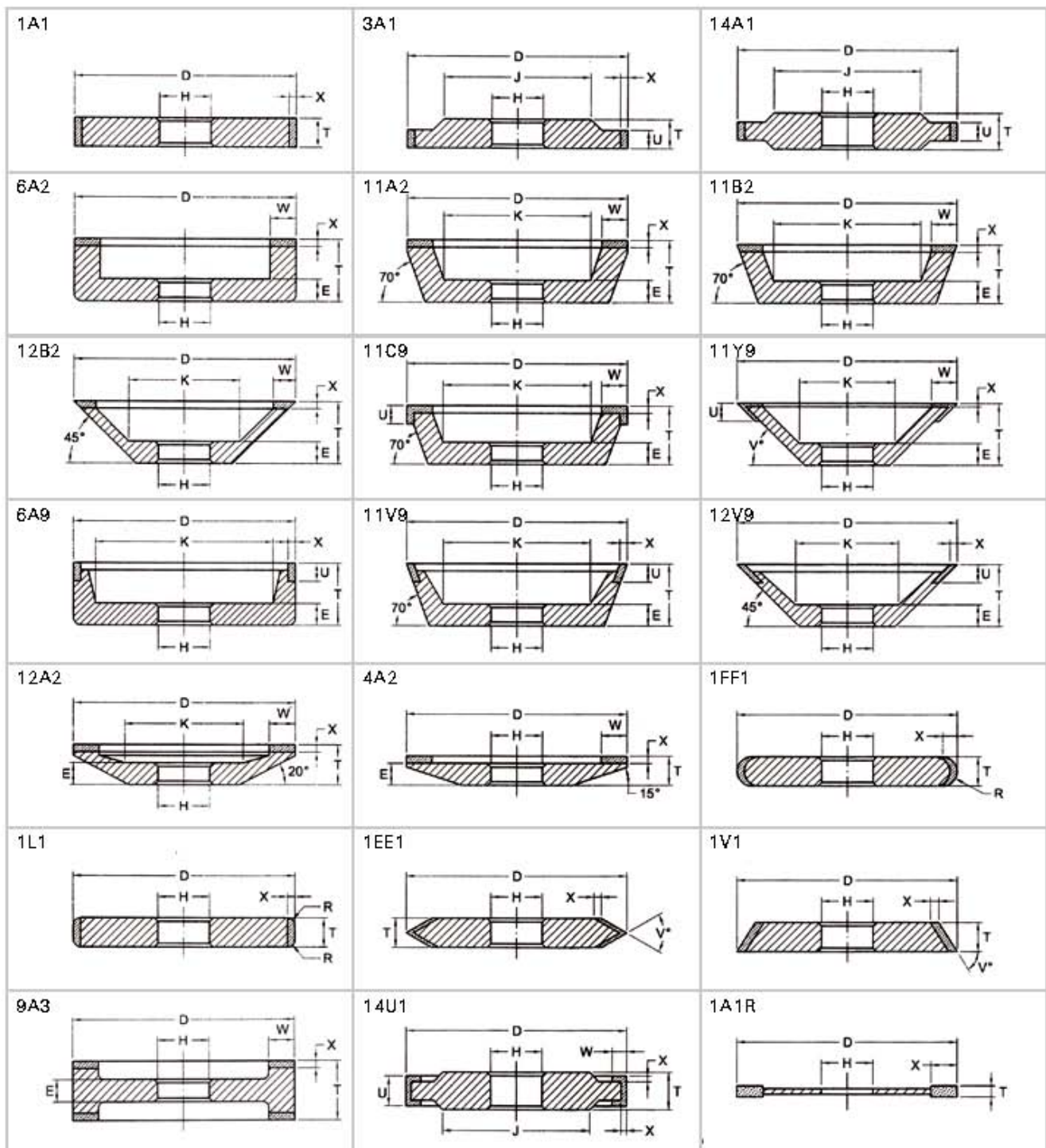

### 砂輪訂製方法 / How to order a wheel?

1. 若是重覆訂製,請告知工作單編號即可。 / For repeated order, just tell us the manufacturing number.
2. 若需我們為您設計砂輪,則請告知: / If you require us to design the wheels for you, please specify:
  - a.) 工件名稱,材質,硬度 / Name, materials, hardness of work-piece.
  - b.) 機器名稱,型式,轉速及馬力 / Name, type, horse power, spindle speed of machine.
  - c.) 加工條件及加工精度 / Grinding conditions.
3. 若自行設計砂輪,則告知如下例: / If you have your own design, please order as below:
 

14A1, 350D-10U-5X-25T-250J-127H, SDC 150N75R5.0, 溼磨 / Wet grinding

# 電鍍鑽石砂輪 / Electroplated Diamond wheels

11C9碗型砂輪	適合鑄鋼工具之研磨，成型用。																																																								
	Ideal for carbide tools grinding, forming and sharpening.																																																								
	<table border="1"> <thead> <tr> <th>編號 Order no.</th> <th>D</th> <th>T</th> <th>W</th> <th>H</th> <th>U</th> <th>粒度 Grit size</th> </tr> </thead> <tbody> <tr> <td>WC-1005A</td> <td>100</td> <td>22</td> <td>10</td> <td>20</td> <td>5</td> <td>#100*</td> </tr> <tr> <td>WC-1005B</td> <td>100</td> <td>35</td> <td>10</td> <td>20</td> <td>5</td> <td>#100*</td> </tr> <tr> <td>WC-1005C</td> <td>100</td> <td>35</td> <td>10</td> <td>19.05</td> <td>5</td> <td>#100*</td> </tr> <tr> <td>WC-1605A</td> <td>100</td> <td>35</td> <td>16</td> <td>20</td> <td>5</td> <td>#200*</td> </tr> <tr> <td>WC-2005A</td> <td>100</td> <td>35</td> <td>20</td> <td>20</td> <td>5</td> <td>#200*</td> </tr> </tbody> </table>	編號 Order no.	D	T	W	H	U	粒度 Grit size	WC-1005A	100	22	10	20	5	#100*	WC-1005B	100	35	10	20	5	#100*	WC-1005C	100	35	10	19.05	5	#100*	WC-1605A	100	35	16	20	5	#200*	WC-2005A	100	35	20	20	5	#200*														
編號 Order no.	D	T	W	H	U	粒度 Grit size																																																			
WC-1005A	100	22	10	20	5	#100*																																																			
WC-1005B	100	35	10	20	5	#100*																																																			
WC-1005C	100	35	10	19.05	5	#100*																																																			
WC-1605A	100	35	16	20	5	#200*																																																			
WC-2005A	100	35	20	20	5	#200*																																																			
1A1U	適合鑄鋼刀具之研磨，成型用。																																																								
	Ideal for carbide tools sharpening.																																																								
	<table border="1"> <thead> <tr> <th>編號 Order no.</th> <th>D</th> <th>T</th> <th>W</th> <th>H</th> <th>粒度 Grit size</th> </tr> </thead> <tbody> <tr> <td>WS-6105A</td> <td>150</td> <td>10</td> <td>5</td> <td>31.75</td> <td>#200*</td> </tr> <tr> <td>WS-6105B</td> <td>150</td> <td>10</td> <td>5</td> <td>12.70</td> <td>#200*</td> </tr> <tr> <td>WS-6105C</td> <td>150</td> <td>10</td> <td>5</td> <td>15.88</td> <td>#200*</td> </tr> </tbody> </table>	編號 Order no.	D	T	W	H	粒度 Grit size	WS-6105A	150	10	5	31.75	#200*	WS-6105B	150	10	5	12.70	#200*	WS-6105C	150	10	5	15.88	#200*																																
編號 Order no.	D	T	W	H	粒度 Grit size																																																				
WS-6105A	150	10	5	31.75	#200*																																																				
WS-6105B	150	10	5	12.70	#200*																																																				
WS-6105C	150	10	5	15.88	#200*																																																				
3Y1	適合鑄鋼刀具之研磨，成型用。																																																								
	Ideal for carbide tools sharpening.																																																								
	<table border="1"> <thead> <tr> <th>編號 Order no.</th> <th>D</th> <th>U</th> <th>T</th> <th>W</th> <th>H</th> <th><math>V^\circ</math></th> <th>粒度 Grit size</th> </tr> </thead> <tbody> <tr> <td>WV-6645A</td> <td>150</td> <td>6</td> <td>10</td> <td>5</td> <td>12.70</td> <td>45</td> <td>#200*</td> </tr> <tr> <td>WV-6645B</td> <td>150</td> <td>6</td> <td>10</td> <td>5</td> <td>15.88</td> <td>45</td> <td>#200*</td> </tr> <tr> <td>WV-6660A</td> <td>150</td> <td>6</td> <td>10</td> <td>5</td> <td>12.70</td> <td>60</td> <td>#200*</td> </tr> <tr> <td>WV-6660B</td> <td>150</td> <td>6</td> <td>10</td> <td>5</td> <td>15.88</td> <td>60</td> <td>#200*</td> </tr> </tbody> </table>	編號 Order no.	D	U	T	W	H	$V^\circ$	粒度 Grit size	WV-6645A	150	6	10	5	12.70	45	#200*	WV-6645B	150	6	10	5	15.88	45	#200*	WV-6660A	150	6	10	5	12.70	60	#200*	WV-6660B	150	6	10	5	15.88	60	#200*																
編號 Order no.	D	U	T	W	H	$V^\circ$	粒度 Grit size																																																		
WV-6645A	150	6	10	5	12.70	45	#200*																																																		
WV-6645B	150	6	10	5	15.88	45	#200*																																																		
WV-6660A	150	6	10	5	12.70	60	#200*																																																		
WV-6660B	150	6	10	5	15.88	60	#200*																																																		
14A1, 14A1U	適合寶石、半寶石、石材研磨，成型用。																																																								
	Ideal for carbide gem stone and stones grinding.																																																								
	<table border="1"> <thead> <tr> <th>編號 Order no.</th> <th>D</th> <th>T</th> <th>W</th> <th>H</th> <th>粒度 Grit size</th> </tr> </thead> <tbody> <tr> <td>WS-0625A</td> <td>150</td> <td>25</td> <td>-</td> <td>25.4</td> <td>#60*</td> </tr> <tr> <td>WS-0625B</td> <td>150</td> <td>25</td> <td>5</td> <td>25.4</td> <td>#60*</td> </tr> </tbody> </table>	編號 Order no.	D	T	W	H	粒度 Grit size	WS-0625A	150	25	-	25.4	#60*	WS-0625B	150	25	5	25.4	#60*																																						
編號 Order no.	D	T	W	H	粒度 Grit size																																																				
WS-0625A	150	25	-	25.4	#60*																																																				
WS-0625B	150	25	5	25.4	#60*																																																				
14A1U	適合鐵粉心之研磨，成型用。																																																								
	Ideal for ferrite core grinding.																																																								
	<table border="1"> <thead> <tr> <th>編號 Order no.</th> <th>D</th> <th>U</th> <th>T</th> <th>E</th> <th>W</th> <th>H</th> <th>粒度 Grit size</th> </tr> </thead> <tbody> <tr> <td>WS-7063A</td> <td>175</td> <td>6</td> <td>10</td> <td>-</td> <td>3</td> <td>31.75</td> <td>#200*</td> </tr> <tr> <td>WS-7073A</td> <td>175</td> <td>7</td> <td>10</td> <td>-</td> <td>3</td> <td>31.75</td> <td>#200*</td> </tr> <tr> <td>WS-7083A</td> <td>175</td> <td>8</td> <td>10</td> <td>-</td> <td>3</td> <td>31.75</td> <td>#200*</td> </tr> <tr> <td>WS-7093A</td> <td>175</td> <td>9</td> <td>10</td> <td>-</td> <td>3</td> <td>31.75</td> <td>#200*</td> </tr> </tbody> </table>	編號 Order no.	D	U	T	E	W	H	粒度 Grit size	WS-7063A	175	6	10	-	3	31.75	#200*	WS-7073A	175	7	10	-	3	31.75	#200*	WS-7083A	175	8	10	-	3	31.75	#200*	WS-7093A	175	9	10	-	3	31.75	#200*																
編號 Order no.	D	U	T	E	W	H	粒度 Grit size																																																		
WS-7063A	175	6	10	-	3	31.75	#200*																																																		
WS-7073A	175	7	10	-	3	31.75	#200*																																																		
WS-7083A	175	8	10	-	3	31.75	#200*																																																		
WS-7093A	175	9	10	-	3	31.75	#200*																																																		
9A1U																																																									
	<table border="1"> <tbody> <tr> <td>WS-7103A</td> <td>175</td> <td>-</td> <td>10</td> <td>9.8</td> <td>3</td> <td>31.75</td> <td>#200*</td> </tr> <tr> <td>WS-7113A</td> <td>175</td> <td>-</td> <td>11</td> <td>10</td> <td>3</td> <td>31.75</td> <td>#200*</td> </tr> <tr> <td>WS-7123A</td> <td>175</td> <td>-</td> <td>12</td> <td>10</td> <td>3</td> <td>31.75</td> <td>#200*</td> </tr> <tr> <td>WS-7133A</td> <td>175</td> <td>-</td> <td>13</td> <td>10</td> <td>3</td> <td>31.75</td> <td>#200*</td> </tr> <tr> <td>WS-7143A</td> <td>175</td> <td>-</td> <td>14</td> <td>10</td> <td>3</td> <td>31.75</td> <td>#200*</td> </tr> <tr> <td>WS-7153A</td> <td>175</td> <td>-</td> <td>15</td> <td>10</td> <td>3</td> <td>31.75</td> <td>#200*</td> </tr> <tr> <td>WS-7163A</td> <td>175</td> <td>-</td> <td>16</td> <td>10</td> <td>3</td> <td>31.75</td> <td>#200*</td> </tr> </tbody> </table>	WS-7103A	175	-	10	9.8	3	31.75	#200*	WS-7113A	175	-	11	10	3	31.75	#200*	WS-7123A	175	-	12	10	3	31.75	#200*	WS-7133A	175	-	13	10	3	31.75	#200*	WS-7143A	175	-	14	10	3	31.75	#200*	WS-7153A	175	-	15	10	3	31.75	#200*	WS-7163A	175	-	16	10	3	31.75	#200*
WS-7103A	175	-	10	9.8	3	31.75	#200*																																																		
WS-7113A	175	-	11	10	3	31.75	#200*																																																		
WS-7123A	175	-	12	10	3	31.75	#200*																																																		
WS-7133A	175	-	13	10	3	31.75	#200*																																																		
WS-7143A	175	-	14	10	3	31.75	#200*																																																		
WS-7153A	175	-	15	10	3	31.75	#200*																																																		
WS-7163A	175	-	16	10	3	31.75	#200*																																																		

說明 / Note : "\*" 標準粒度,其餘粒度請指明訂購。

"\*" Standard grit size, others depend on your request.

# 樹脂鑽石砂輪 / Resinoid Diamond & CBN Wheels

11A2		<p>適用於工具磨床，鑄鋼刀具研磨及成型 - Apply on tool grinding machine, to grind or form the carbide tools.</p>																																																																																																
	<table border="1"> <thead> <tr> <th>編號 Order no.</th> <th>D</th> <th>W</th> <th>X</th> <th>T</th> <th>H</th> <th>粒度 Grit size</th> </tr> </thead> <tbody> <tr> <td>RD-04082A</td> <td>100</td> <td>8</td> <td>2</td> <td>40</td> <td>20</td> <td>SDC-150</td> </tr> <tr> <td>RD-04103A</td> <td>100</td> <td>10</td> <td>3</td> <td>30</td> <td>20</td> <td>SDC-200</td> </tr> <tr> <td>RD-04103C</td> <td>100</td> <td>10</td> <td>3</td> <td>30</td> <td>19.05</td> <td>SDC-200</td> </tr> </tbody> </table>	編號 Order no.	D	W	X	T	H	粒度 Grit size	RD-04082A	100	8	2	40	20	SDC-150	RD-04103A	100	10	3	30	20	SDC-200	RD-04103C	100	10	3	30	19.05	SDC-200																																																																					
編號 Order no.	D	W	X	T	H	粒度 Grit size																																																																																												
RD-04082A	100	8	2	40	20	SDC-150																																																																																												
RD-04103A	100	10	3	30	20	SDC-200																																																																																												
RD-04103C	100	10	3	30	19.05	SDC-200																																																																																												
11C9		<p>適用於工具磨床，鑄鋼刀具研磨及成型 - Apply on tool grinding machine, to grind or form the carbide tools.</p>																																																																																																
	<table border="1"> <thead> <tr> <th>編號 Order no.</th> <th>D</th> <th>W</th> <th>X</th> <th>U</th> <th>T</th> <th>H</th> <th>粒度 Grit size</th> </tr> </thead> <tbody> <tr> <td>RD-04815A</td> <td>100</td> <td>8</td> <td>1</td> <td>5</td> <td>40</td> <td>20</td> <td>SDC-150</td> </tr> </tbody> </table>	編號 Order no.	D	W	X	U	T	H	粒度 Grit size	RD-04815A	100	8	1	5	40	20	SDC-150																																																																																	
編號 Order no.	D	W	X	U	T	H	粒度 Grit size																																																																																											
RD-04815A	100	8	1	5	40	20	SDC-150																																																																																											
12Y9C		<p>適用於自動車床刀具研磨機，鑄鋼車刀研磨 - For tool grinding machine, to sharpen the carbide turning tools.</p>																																																																																																
	<table border="1"> <thead> <tr> <th>編號 Order no.</th> <th>D</th> <th>W</th> <th>U</th> <th>X</th> <th>T</th> <th>H</th> <th>V°</th> <th>形狀 Shape</th> <th>粒度 Grit size</th> </tr> </thead> <tbody> <tr> <td>RD-05815A</td> <td>125</td> <td>8</td> <td>-</td> <td>1</td> <td>16</td> <td>25</td> <td>-</td> <td>12A2C</td> <td>SDC-400</td> </tr> <tr> <td>RD-05815B</td> <td>125</td> <td>8</td> <td>5</td> <td>1</td> <td>16</td> <td>25</td> <td>60°</td> <td>12Y9C</td> <td>SDC-600</td> </tr> <tr> <td>RD-05815C</td> <td>125</td> <td>8</td> <td>5</td> <td>1</td> <td>16</td> <td>25</td> <td>45°</td> <td>12Y9C</td> <td>SDC-400</td> </tr> </tbody> </table>	編號 Order no.	D	W	U	X	T	H	V°	形狀 Shape	粒度 Grit size	RD-05815A	125	8	-	1	16	25	-	12A2C	SDC-400	RD-05815B	125	8	5	1	16	25	60°	12Y9C	SDC-600	RD-05815C	125	8	5	1	16	25	45°	12Y9C	SDC-400																																																									
編號 Order no.	D	W	U	X	T	H	V°	形狀 Shape	粒度 Grit size																																																																																									
RD-05815A	125	8	-	1	16	25	-	12A2C	SDC-400																																																																																									
RD-05815B	125	8	5	1	16	25	60°	12Y9C	SDC-600																																																																																									
RD-05815C	125	8	5	1	16	25	45°	12Y9C	SDC-400																																																																																									
1A1		<p>適用於平面磨床，研磨鑄鋼、陶瓷(SDC)或硬化鋼材(BC) - Apply on surface grinding machine, to grind carbide(SDC) or hardened steels(BC).</p>																																																																																																
14A1		<table border="1"> <thead> <tr> <th>編號 Order no.</th> <th>D</th> <th>U</th> <th>X</th> <th>T</th> <th>H</th> <th>形狀 Shape</th> <th>粒度 Grit size</th> </tr> </thead> <tbody> <tr> <td>RD-06033A</td> <td>150</td> <td>3</td> <td>3</td> <td>10</td> <td>31.75</td> <td>14A1</td> <td>SDC-150</td> </tr> <tr> <td>RB-06033A</td> <td>150</td> <td>3</td> <td>3</td> <td>10</td> <td>31.75</td> <td>14A1</td> <td>BC-150</td> </tr> <tr> <td>RD-06063A</td> <td>150</td> <td>6</td> <td>3</td> <td>10</td> <td>31.75</td> <td>14A1</td> <td>SDC-150</td> </tr> <tr> <td>RB-06063A</td> <td>150</td> <td>6</td> <td>3</td> <td>10</td> <td>31.75</td> <td>14A1</td> <td>BC-150</td> </tr> <tr> <td>RD-06083A</td> <td>150</td> <td>8</td> <td>3</td> <td>10</td> <td>31.75</td> <td>14A1</td> <td>SDC-150</td> </tr> <tr> <td>RD-06103A</td> <td>150</td> <td>-</td> <td>3</td> <td>10</td> <td>31.75</td> <td>1A1</td> <td>SDC-150</td> </tr> <tr> <td>RB-06103A</td> <td>150</td> <td>-</td> <td>3</td> <td>10</td> <td>31.75</td> <td>1A1</td> <td>BC-150</td> </tr> <tr> <td>RD-06063A</td> <td>175</td> <td>6</td> <td>3</td> <td>10</td> <td>31.75</td> <td>14A1</td> <td>SDC-150</td> </tr> <tr> <td>RD-07103A</td> <td>175</td> <td>-</td> <td>3</td> <td>10</td> <td>31.75</td> <td>1A1</td> <td>SDC-150</td> </tr> <tr> <td>RB-07103A</td> <td>175</td> <td>-</td> <td>3</td> <td>10</td> <td>31.75</td> <td>1A1</td> <td>BC-150</td> </tr> <tr> <td>RB-07133A</td> <td>175</td> <td>-</td> <td>3</td> <td>13</td> <td>31.75</td> <td>1A1</td> <td>BC-150</td> </tr> </tbody> </table>	編號 Order no.	D	U	X	T	H	形狀 Shape	粒度 Grit size	RD-06033A	150	3	3	10	31.75	14A1	SDC-150	RB-06033A	150	3	3	10	31.75	14A1	BC-150	RD-06063A	150	6	3	10	31.75	14A1	SDC-150	RB-06063A	150	6	3	10	31.75	14A1	BC-150	RD-06083A	150	8	3	10	31.75	14A1	SDC-150	RD-06103A	150	-	3	10	31.75	1A1	SDC-150	RB-06103A	150	-	3	10	31.75	1A1	BC-150	RD-06063A	175	6	3	10	31.75	14A1	SDC-150	RD-07103A	175	-	3	10	31.75	1A1	SDC-150	RB-07103A	175	-	3	10	31.75	1A1	BC-150	RB-07133A	175	-	3	13	31.75	1A1	BC-150
編號 Order no.	D	U	X	T	H	形狀 Shape	粒度 Grit size																																																																																											
RD-06033A	150	3	3	10	31.75	14A1	SDC-150																																																																																											
RB-06033A	150	3	3	10	31.75	14A1	BC-150																																																																																											
RD-06063A	150	6	3	10	31.75	14A1	SDC-150																																																																																											
RB-06063A	150	6	3	10	31.75	14A1	BC-150																																																																																											
RD-06083A	150	8	3	10	31.75	14A1	SDC-150																																																																																											
RD-06103A	150	-	3	10	31.75	1A1	SDC-150																																																																																											
RB-06103A	150	-	3	10	31.75	1A1	BC-150																																																																																											
RD-06063A	175	6	3	10	31.75	14A1	SDC-150																																																																																											
RD-07103A	175	-	3	10	31.75	1A1	SDC-150																																																																																											
RB-07103A	175	-	3	10	31.75	1A1	BC-150																																																																																											
RB-07133A	175	-	3	13	31.75	1A1	BC-150																																																																																											
1A1R		<p>適用於平面磨床(phi 31.75孔)或沖頭切斷機(phi 19.05孔) - 用於切斷鑄鋼、陶瓷(SDC)或硬化鋼材(BC) - Apply on surface grinding machine or cutting machine, to cut the carbide, ceramics(SDC) or hardened steels(BC)</p>																																																																																																
	<table border="1"> <thead> <tr> <th>編號 Order no.</th> <th>D</th> <th>T</th> <th>X</th> <th>H</th> <th>粒度 Grit size</th> </tr> </thead> <tbody> <tr> <td>RD-06017A</td> <td>150</td> <td>1.0</td> <td>7</td> <td>31.75</td> <td>SDC-120</td> </tr> <tr> <td>RB-06017A</td> <td>150</td> <td>1.0</td> <td>7</td> <td>31.75</td> <td>BC-120</td> </tr> <tr> <td>RD-06017B</td> <td>150</td> <td>1.0</td> <td>7</td> <td>19.05</td> <td>SDC-120</td> </tr> </tbody> </table>	編號 Order no.	D	T	X	H	粒度 Grit size	RD-06017A	150	1.0	7	31.75	SDC-120	RB-06017A	150	1.0	7	31.75	BC-120	RD-06017B	150	1.0	7	19.05	SDC-120																																																																									
編號 Order no.	D	T	X	H	粒度 Grit size																																																																																													
RD-06017A	150	1.0	7	31.75	SDC-120																																																																																													
RB-06017A	150	1.0	7	31.75	BC-120																																																																																													
RD-06017B	150	1.0	7	19.05	SDC-120																																																																																													

說明 / Note : "※" 標準粒度,其餘粒度請指明訂購。  
"※" Standard grit size, others depend on your request.

# 聚晶鑽石、氮化硼車刀 / PCD & PCBN Turning Tools



## 應用範圍：

- 聚晶鑽石 (PCD)
  - 銅合金、鋁合金
  - 燒結碳化鎢及陶瓷
  - 預燒結碳化鎢及陶瓷
  - 高矽鋁合金
  - F.R.P、硬橡膠、石墨
- 聚晶氮化硼 (PCBN)
  - 硬化鋼材 [HRC 45 - 68]
  - 耐熱鋼 (SUS)
  - 超耐熱鋼：鎳基合金、鈷基合金
  - 鑄鐵：冷激鑄鐵、捷硬鑄鐵
  - 燒結合金鋼：鎢鉻鋼、鎢鉻鉕鋼

聚晶鑽石和聚晶氮化硼車刀與其他切削刀具比較，具有較高之硬度及耐磨耗性，其優點如下：有較長之刀具壽命，提高工件加工精度及表面光潔度，降低工件加工成本以及提高機器生產力。

PCD & PCBN have higher hardness & abrasion resistance than other cutting tools. The advantages of these features are: improving tool's life, providing better control over part size and surface finishes, reducing tool cost per machined part and improving machine productivity.

## Applications:

- Polycrystalline Diamond (PCD)
  - Aluminum alloys, copper alloys, manganese alloys
  - Sintered carbide & ceramics
  - Green or semi-sintered carbide & ceramics
  - High-silicon aluminum alloys
  - Reinforced plastic, hard rubber, carbon, graphite
- Polycrystalline Cubic Boron Nitride (PCBN)
  - Hardened steels [HRC 45 - 68]
  - Tempering steels
  - Super alloys: Cobalt and nickel base super alloys
  - Cast iron: Chilled iron, Meehanite iron
  - Sintered ferrous alloys: SCM, SNCM

## 規格 / Specifications:

單位 / Unit : mm

編號 Order no.	刀片材質 Tip material	W	H	L	R	V*	S
 31型	B4612-4G	PCBN	16	16	120	0.4	0
	B4613-4G	PCBN	19	19	140	0.4	0
 33型	D6732-5A	PCD	16	16	120	0.5	0
	D6733-5A	PCD	19	19	140	0.5	0
	B6630-4G	PCBN	10	10	80	0.4	0
	B6631-4G	PCBN	13	13	100	0.4	0
	B6632-4G	PCBN	16	16	120	0.4	0
	D6530-3F	PCD	10	10	80	0.3	10
	D6531-3F	PCD	13	13	100	0.3	10
D6532-3F	PCD	16	16	120	0.3	10	
 34型	D6540-3F	PCD	10	10	80	0.3	10
	D6541-3F	PCD	13	13	100	0.3	10
	D6542-3F	PCD	16	16	120	0.3	10
 35型	D6752-5A	PCD	16	16	120	0.5	0
	D6753-5A	PCD	19	19	140	0.5	0
	B6650-4G	PCBN	10	10	80	0.4	0
	B6651-4G	PCBN	13	13	100	0.4	0
	B6652-4G	PCBN	16	16	120	0.4	0
	D6650-3F	PCD	10	10	80	0.3	10
	D6651-3F	PCD	13	13	100	0.3	10
D6652-3F	PCD	16	16	120	0.3	10	
 37型	D6772-5A	PCD	16	16	120	0.5	0
	D6673-5A	PCD	19	19	140	0.5	0
	B6672-4G	PCBN	16	16	120	0.4	0
	B6673-4G	PCBN	19	19	140	0.4	0
	D6571-3F	PCD	13	13	100	0.3	10
	D6572-3F	PCD	16	16	120	0.3	10

說明 / Note: 其他規格之車刀,請提供詳細圖面訂購。

The turning tools with other specification, please offer detail drawing when ordering.

# 犀利盾® 纖維油石 / Ceramic Fiber Stones



## 粒度與顏色 / Grit Size & Color Code:

粒度 / Grit Size	#180	#250	#280	#360	#400	#700	#1000	#1200
顏色 Color	咖啡色 Brown	橘色 Orange	黑色 Black	海軍藍 Navy Blue	藍色 Blue	黃色 Yellow	白色 White	紅色 Red
代號 / Code	C	O	D	N	B	Y	W	R

## 規格 / Specifications:



單位 / Unit : mm

T x W x L (ø D x L)	粒度與編號 Grit Size & Order No.							
	#180	#250	#280	#360	#400	#700	#1000	#1200
1 x 4 x 100	CSC-1004	CSO-1004	CSD-1004	CSN-1004	CSB-1004	CSY-1004	CSW-1004	CSR-1004
1 x 6 x 100	CSC-1006	CSO-1006	CSD-1006	CSN-1006	CSB-1006	CSY-1006	CSW-1006	CSR-1006
1 x 10 x 100	CSC-1010	CSO-1010	CSD-1010	CSN-1010	CSB-1010	CSY-1010	CSW-1010	CSR-1010
ø 3.0 x 100	CGC-30	CGO-30	CGD-30	CGN-30	CGB-30	CGY-30	CGW-30	CGR-30

## 粒度使用與建議 / Recommendation:

粒度 / Grit Size	使用建議 Applications
#180, #250, #280	機具放電加工後之硬化表層去除及機械切削粗糙刀痕之去除。 To remove the rough machining surface or hard EDM scale of tool and die steels.
#360, #400	細微加工痕跡之去除及一般拋磨。 General lapping of finer surface scratch line of tool & die steels.
#700, #1000, #1200	精細研磨或鏡面處理前之拋光。 Fine polishing & finishing.
ø 3.0 mm 圓柱 / Round	可搭配刺磨機當成研磨棒使用 (長度勿超過 50mm 長), 亦可將之磨尖用於細微角 落或窄縫處之研磨。 It can be used like grinding point (max. length 50mm), or by sharpening it for detail lapping.

使用纖維油石時，應將工具與工件成30°-45°，則磨研效果最佳。In order to reach the best performance, we recommend that the stone should be held up-right by making an angle of approx. 30°-45° to the work-piece.

## 迷你纖維油石 / Mini Ceramic Fiber Stones

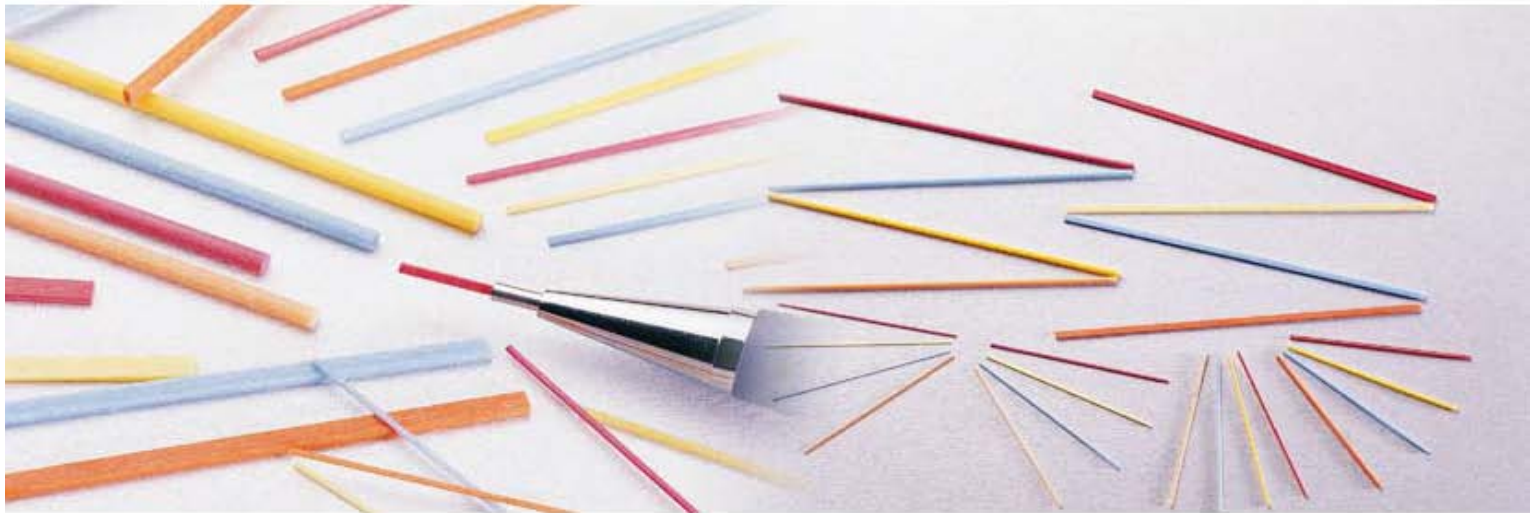

迷你纖維油石是將纖維油石切成微細尺寸，從0.5 x 0.5mm到1 x 2mm。專門使用於各種模具之細微部位或是其他類似之加工。由於陶瓷纖維具有高抗折強度，可解決一般油石或紅寶石易斷的困擾。

用途：

迷你纖維油石可適用於各種模具之研磨及各種零件之精細拋光。尤其是雕刻部位之加工，微小肋部，模具角部精細拋磨，以及各種微細或複雜部位之加工。

**Mini Ceramic Fiber Stones** are cut by ceramic fiber stone, their size from 0.5 x 0.5 mm to 1 x 2mm. Ideal for various mold and dies detail lapping.

**Traditional oil stone** and ruby stones in such a small sizes are very easy to break, while mini ceramic stone provide high strength and high elasticity. Due to its hard to break, they resolve the problem of using these stones.

### Applications

It is good for all type of molds and dies fine and super fine finishing. Especially for engraving parts, slight ribs, R ribs, corners, complicated area and details.

Besides, all other tool parts that needs details lapping, Our mini ceramic fiber stone will be the wonderful tools.

### 規格 / Specifications:

尺寸 (mm) Dimensions (mm)	粒度與編號 Grit Size & Order No.				使用夾頭 Holder
	#250	#400	#700	#1200	
0.5 x 0.5 x 50L	MOS-055	MBS-055	MYS-055	MRS-055	XH-007
0.7 x 0.7 x 50L	MOS-075	MBS-075	MYS-075	MRS-075	XH-009
0.9 x 0.9 x 50L	MOS-095	MBS-095	MYS-095	MRS-095	XH-013
1.0 x 2.0 x 100L	MOS-121	MBS-121	MYS-121	MRS-121	XH-200
ø 0.9 x 50L	MOG-105	MBG-105	MYG-105	MRG-105	XH-009
ø 2.0 x 100L	MOG-201	MBG-201	MYG-201	MRG-201	XH-200

### Application Example



## 油石夾柄 / Tool Holders



單位 / Unit : mm

編號 Order No.	可挾持尺寸 Holding Capacity	運用 Applications
XH-007	Square 0.5 x 0.5 or Round $\varnothing$ 0.7	迷你纖維油石 For Mini Fiber Stone
XH-009	Square 0.7 x 0.7 or Round $\varnothing$ 0.9	迷你纖維油石 For Mini Fiber Stone
XH-200	Flat 2 x 1 or Round $\varnothing$ 2.0	迷你纖維油石 For Mini Fiber Stone
XH-013	Square 0.9 x 0.9 or Round $\varnothing$ 1.3	迷你纖維油石 For Mini Fiber Stone
XH-22	Round 3.0	纖維油石 For Fiber Stone
XH-041	平形/ Flat 4 x 1	纖維油石 For Fiber Stone
XH-061	平形/ Flat 6 x 1	纖維油石 For Fiber Stone
XH-101	平形/ Flat 10 x 1	纖維油石 For Fiber Stone
XH-062	平形/ Flat 6 x 2 - 6 x 3	一般油石 For Oil Stone
XH-133	平形/ Flat 13 x 3	一般油石 For Oil Stone
XH-136	平形/ Flat 13 x 6.3	一般油石 For Oil Stone

# 帶柄砂輪 / Mounted Points



規格 / Specifications:

單位 / Unit : mm

256A	308A	410A	510A	612A	816A	1016A*	30B	40B
50B	60B	80B	100B	120B	308T	310T	412T	710T
813R	1224R*	609S	412J	616J	816J	1016J	612P	815P
1018P*	308K	412K	515K	816K	132E	133E	162E*	163E*

說明 / Note:

- 標準柄徑為 $\varnothing 3.0\text{mm}$ ,其他柄徑為 $\varnothing 2.34\text{mm}$ 或 $\varnothing 3.175$ ,請指明訂購。  
 $\varnothing 3.0\text{mm}$  shank is standard, others ( $\varnothing 2.34$  or  $\varnothing 3.175\text{mm}$ ) depend on request.
- 有\*之尺寸,無法提供 $\varnothing 2.34\text{mm}$ 柄。  
 The tools with "\*" marked, just available for  $\varnothing 3.0$  &  $\varnothing 3.175$  shank.



# 油石 / Oil Polishing Stones

## 彈性帶柄砂輪 / Elastic Mounted Points

### 油石 / Oil Polishing Stones:

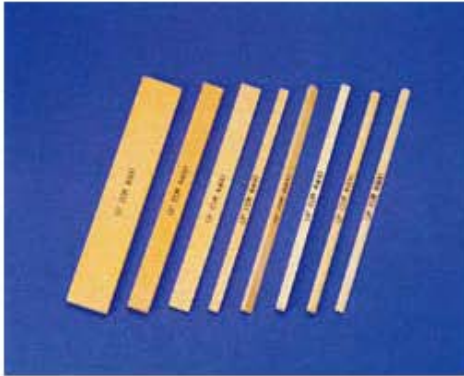

- **EDM** 系列油石：  
主要用來去除各種模具EDM加工後之硬化表層。
- **DF** 系列油石：  
主要使用於一般模具機械加工之痕跡去除及拋光作業。
- **EDM** series stones are specially for removing the hard scale generated by the EDM process on all type of mold and die steels.
- **DF** series stones are suitable for removing the machined surface scratch and general lapping & polishing all mold and die steels.

### 尺寸 / Dimensions:

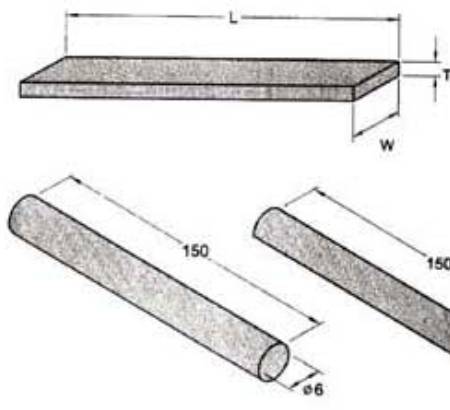

W x T x L : 25 x 6 x 150 · 25 x 3 x 150 · 13 x 13 x 150  
13 x 6 x 150 · 13 x 3 x 150 · 13 x 1.6 x 150  
6 x 6 x 150 · 6 x 3 x 150 · 10 x 10 x 150

粒度 / Grit size : #120 · #180 · #220 · #320 · #400 · #600 · #800 · #1000

### 彈性帶柄砂輪 / Elastic Mounted Points:

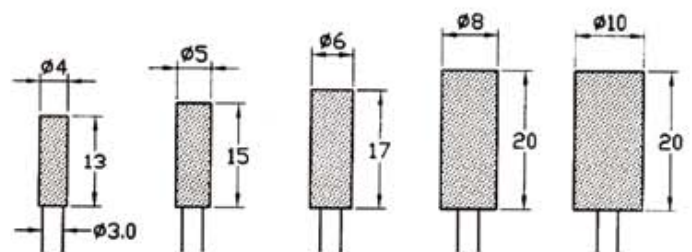

單位 / Unit : mm

	粒度/Grit size	編號/Order no.				
牛皮砂輪/Resinoid point	#120	N413	N515	N617	N820	N1020
海綿砂輪/Rubberize point	#120	R413	R515	R617	R820	R1020

# 超音波振動研磨機 / Ultrasonic Lapping Machine

Ultrasonic Lapping Machine with micro vibration stroke and extra-high frequency (22,000 times per second), which can easily handle most intricate jobs for various molds and dies.

The difficult traditional process of slots, ribs, detail corners, intricate areas becomes so easy with time saving, and efficiently reach a quality result of polishing and finishing process.

## Features:

- \* Powerful output :  
Max.45 watts of output power enables you to achieve any polishing task at the best performance.
- \* Auto feedback system :  
Machine itself will automatically adjust frequency according to different tools to get the best performance.
- \* Electronic transformer with regulation :  
To maintain the machine in good performance and protect it from damage even at an unstable supply of electric voltage.
- \* Detecting circuit of suspending :  
When handpiece is not in used, the unit will automatically reduce the output power. It does not only prolong the life of the handpiece transducer but also keep the tools from heating up .

超音波振動研磨機，以每秒兩萬多次的超高頻微細振動，可輕鬆地解決各種模具的複雜或細微部位之加工。

以前難以加工的溝槽、肋骨、角落或複雜及微細等部位，現在使用超音波振動研磨機，將可有效地且省時地完成各種模具之研磨及拋光工作。

## 特長：

- \* 強勁的輸出功率：最大45瓦的輸出功率，提供有效且快速之加工作業。
- \* 自動追尾迴路：機器會根據各種不同工具，自動檢測並選擇最佳之輸出振頻以發揮各種工具之最佳性能。
- \* 電子穩壓變壓器：電子變壓器兼具穩壓效果，即使在電源不穩定之情況下，依然可維持機器良好的操作性能，且可保護機器不致受損。
- \* 空振檢知迴路設計：當手機未與工件接觸時，機器會自動降低輸出功率，以延長手機壽命，並可防止工具因空振導致發燙或燒毀。

## 規格 / Specifications:

編號 / Order no.	AR-108	AR-208	AR-303
電源控制器	Power Controller :		
電源	Main supply: AC 90V ~ 250V ± 10%, 50/60 Hz		
超音波輸出	Ultrasonic output: 36 watts, 2-level	45 watts, 5-level	45 watts, 5-level
直流馬達輸出	Output for DC motor: 無 / None	無 / None	0 ~ 30V, 10-level
振頻	Vibration frequency: 18 ~ 25 kHz	18 ~ 26 kHz	18 ~ 26 kHz
振幅	Stroke amplitude: 10 ~ 35um	3 ~ 40um	3 ~ 40um
振頻調整	Frequency adjustment: 自動追尾系統 / Automatic feed-back system		
消耗電力	Power consumption: 46 watts	60 watts	60 watts
保險絲	Fuse: 2 A	2 A	2 A
尺寸	Dimensions (W x D x H): 192x156x96mm	225x178x110mm	168x252x210 mm
重量	Weight: 0.6 kg	2.5 kg	2.6 kg
手機	Handpiece:		
超音波手機	Ultrasonic handpiece : GS-H01	GS-H02	GS-H03
尺寸	Dimensions (øD x L) ø30 x 131mm	ø33 x 145 mm	ø33 x 145 mm
重量	Weight : 185g	260g	260g
旋轉手機	Rotary handpiece : -	-	U-Lap 40
尺寸	Dimensions (øD x L) -	-	ø31.6x164 mm
重量	Weight : -	-	275g

## 超音波振動研磨機 / Ultrasonic Lapping Machine



### AR-108 經濟型 / Economic type

- A new design machine with a reliable quality and good performance.
- Attractive price would absolutely change your image of an expensive ultrasonic unit.
- Not only effective for lapping but also slithering printed circuit board (PCB) for circuit amendment.
- 具有可信賴的品質及良好性能的全新設計機種。
- 誘人的價格，打破超音波研磨機是很昂貴的觀念。
- 除了超音波研磨外，且可用於電子業，做電路板(PCB)之電子迴路修改及寶石業之精細雕刻、研磨。



### AR-208 單功能型 / Single Function type

- Ultrasonic polishing only.
- Max.45 watts output, provide excellent polishing and finishing performance.
- 5 level ultrasonic output to suit difference type of tools and polishing works.
- 超音波研磨單功能機。
- 最大45瓦之輸出，提供高效率的研磨、拋光性能。
- 5段超音波功率輸出，滿足各種加工需求。



### AR-303 雙功能型 / Dual-function type

- This dual-function machine provides you the versatility of both ultrasonic and mechanical polishing.
- Max.45 watts output, provide excellent polishing and finishing performance.
- Standard unit supplied with one each of ultrasonic and straight rotary handpiece, other mechanical handpiece can be supplied upon your requirement.
- 5-level ultrasonic and 10-level DC motor output to suit different type of tools and polishing works.
- 超音波及電動手機雙功率輸出，提供您多重功能之各種研磨及拋光作業。
- 本機器提供超音波、電動旋轉手機，其他的電動手機亦可供應。
- 最大45瓦之輸出，提供高效率的研磨、拋光性能。
- 5段超音波及10段DC馬達功率輸出，提供更完整的加工需求。



轉速 / Speed : 60,000 rpm  
重量 / Weight : 110 g  
尺寸 / Dimensions :  $\varnothing 20 \times 160L$  (mm)

## UG-500 精密型 / Precision type

- High-torque, quiet-running and well balance.
- Ideal for precision grinding and finishing works.
- Replaceable collet chuck :  $\varnothing 3.0\text{mm}$  is standard, the  $\varnothing 2.34$  and  $\varnothing 3.175\text{mm}$  collet are optional.
- 高扭力、低噪音、精密型刻磨機。
- 適用於精密研磨及修整作業。
- 可更換式夾頭：標準夾頭為  $\varnothing 3.0\text{mm}$ ，亦可選購  $\varnothing 2.34$  或  $\varnothing 3.175\text{mm}$  為夾頭。



轉速 / Speed : 60,000 rpm  
重量 / Weight : 130g  
尺寸 / Dimensions :  $\varnothing 17 \times 159L$  (mm)

## UG-400 經濟型 / Economic type

- Reliable quality and competitive price.
- Fixed type collet chuck :  $\varnothing 3.0\text{mm}$  is standard, the tool with  $\varnothing 2.34$  and  $\varnothing 3.175\text{mm}$  collet are optional.
- 經濟型，適用於精密研磨及修整作業。
- 夾頭不可更換：標準品為  $\varnothing 3.0\text{mm}$  夾頭，若須  $\varnothing 2.34$  或  $\varnothing 3.175\text{mm}$  夾頭請指明選購。
- 低耗風量，高扭力，品質佳。



轉速 / Speed : 35,000 rpm  
重量 / Weight : 170 g  
尺寸 / Dimensions :  $\varnothing 22 \times 180L$  (mm)

## UG-300 雙夾頭型 / Dual-Collet type

- High torque, heavy-duty, general-purpose applicable on deburring, chamfering, milling and finishing the welded surfaces...etc.
- Dual collet chuck :  $\varnothing 3.0 / \varnothing 6.0\text{mm}$  is standard, the collet of  $\varnothing 3.175 / \varnothing 6.35\text{mm}$  is optional.
- 重負荷、高扭力，泛用型適於清除毛邊倒角、鑄鋼刀銼磨及焊接面磨除等。
- 雙夾頭兩用型：標準為  $\varnothing 3.0 / \varnothing 6.0\text{mm}$  夾頭，其他  $\varnothing 3.175 / \varnothing 6.35\text{mm}$  為選購。

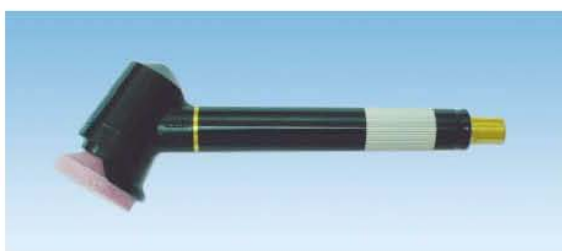

轉速 / Free Speed at 90 psi : 22,000 rpm  
夾頭 / Collet chuck : M7 screw shaft / M7螺桿  
重量 / Weight : 200 g  
尺寸 / Dimensions :  $\varnothing 16.5 \times 136L$  (mm)

## GP-522 平面研磨機 / Angle Surface grinder

- 120 degree angle surface grinder.
- Collet chuck: M7 screw shaft for mounting abrasive cup sheets and abrasive paper disc.
- Ideal for surface grinding, chamfering, deburring and finishing the welded surfaces...etc.
- 適用於平面研磨，倒角及焊接面之修整。
- 夾頭：M7螺桿，可鎖接碗形輪或砂布片。

## U-Lap® 氣動刻磨機 / Air Grinders



轉速 / Speed : 60,000 rpm  
重量 / Weight : 180 g  
尺寸 / Dimensions :  $\varnothing 17.5 \times 142L$  (mm)

### GP-260 精密型 / Precision type

- High-torque, quiet-running and well balance.
- Ideal for precision grinding and finishing works.
- Fixed type collet chuck:  $\varnothing 3.0\text{mm}$  is standard, the tools with  $\varnothing 2.34\text{mm}$  or  $\varnothing 3.175\text{mm}$  collet are optional.

- 精密型，適用於精密研磨及修整作業。
- 夾頭不可更換：標準品為  $\varnothing 3.0\text{mm}$  夾頭， $\varnothing 2.34$  或  $\varnothing 3.175\text{mm}$  請指明選購。



轉速 / Speed : 80,000 rpm  
重量 / Weight : 160 g  
尺寸 / Dimensions :  $\varnothing 20.3 \times 143L$  (mm)

### GP-380 高速型 / High speed type

- High speed, quiet-running and well balance.
- Ideal for precision grinding and finishing works.
- Replaceable collet chuck:  $\varnothing 3.0\text{mm}$  is standard, the collet of  $\varnothing 2.34\text{mm}$  or  $\varnothing 3.175\text{mm}$  collet are optional.

- 高轉速、精密型刻磨機。
- 適用於精密研磨及雕刻作業。
- 可更換式夾頭：標準品為  $\varnothing 3.0\text{mm}$  夾頭， $\varnothing 2.34$  或  $\varnothing 3.175\text{mm}$  為選購。



轉速 / Speed : 23,500 rpm  
重量 / Weight : 180g  
尺寸 / Dimensions :  $\varnothing 17 \times 153L \times 50H$  (mm)

### AG-45 平面研磨機 / Angle surface grinder

- 45 degree angle surface grinder.
- Collet chuck: M7 screw shaft for mounting abrasive cup wheels and abrasive paper disc.
- Ideal for surface grinding, chamfering, deburring and finishing the welded surfaces...etc.

- 45度彎頭平面研磨機，適用於平面研磨，倒角及焊接面之修整。
- 夾頭：M7螺桿，可鎖接碗形輪或砂布片。



轉速 / Speed : 23,500 rpm  
重量 / Weight : 170 g  
尺寸 / Dimensions :  $\varnothing 17 \times 140L \times 39H$  (mm)

### AG-90 平面研磨機 / Angle surface grinder

- 90 degree angle surface grinder.
- Collet chuck: M7 screw shaft for mounting abrasive cup wheels and abrasive paper disc.
- Ideal for surface grinding, chamfering, deburring and finishing the welded surfaces...etc.

- 90度彎頭平面研磨機，適用於平面研磨，倒角及焊接面之修整。
- 夾頭：M7螺桿，可鎖接碗形輪或砂布片。

# U-Lap® 氣動銼磨機 / Pneumatic Reciprocating Lappers



行程 / Stroke : 0.15mm  
 速度 / Speed : 35,000 spm.  
 重量 / Weight : 190g  
 尺寸 / Dimensions :  $\varnothing$ 28x200mm

## UTR-20 Micro Stroke Turbo Air Lappers 微行程渦輪式氣動超音波

- High speed, micro stroke(0.15mm) and low vibration.
- It suits for details and corner area's lapping
- 超高速、微動行程(0.15mm)機種，最適於微細部位及邊角部位之研磨。
- 超低振動，加工角落時沒有撞擊感。



行程 / Stroke : 0.3mm  
 速度 / Speed : 30,000 spm.  
 重量 / Weight : 190g  
 尺寸 / Dimensions :  $\varnothing$ 28x200mm

## UTR-30 Turbo Air Lappers 渦輪式氣動超音波

- Driven by turbine air motor.
- Low noise, low vibration and durable tool life.
- UTR-30 suits for detail area's lapping
- 使用氣動渦輪馬達，維修容易。
- 低噪音、低振動、壽命長。
- UTR-30 適合模具細微部分之加工。



行程 / Stroke : 0.7mm  
 速度 / Speed : 28,000 spm.  
 重量 / Weight : 190g  
 尺寸 / Dimensions :  $\varnothing$ 28x200mm

## UTR-70 Turbo Air Lappers 渦輪式氣動超音波

- Driven by turbine air motor.
- Low noise, low vibration and durable tool life.
- UTR-70 suits for general purpose polishing and finishing process of mold and die.
- 使用氣動渦輪馬達，維修容易。
- 低噪音、低振動、壽命長。
- UTR-70適用於高效率及較大面積之研磨。



編號 / Order no.	UR-120	UR-300
行程 / Stroke :	1.2mm	3.0mm
速度 / Speed :	12,000 spm.	10,000 spm.
重量 / Weight :	250g	250g
尺寸 / Dimensions :	$\varnothing$ 18x180mm	$\varnothing$ 18x180mm

## UR-120, UR-300 Recipro Air Lappers 往復式氣動銼磨機

- High-torque, quiet-running and low vibration.
- Long reciprocating stroke suits for lapping big surfaces, and excellent for deburring or chamfering works of die casting parts.
- 高扭力、低噪音、低振動。
- 較長行程適合大面積之研磨，並適合各種鑄件或零件之清除毛邊及倒角。

## U-Lap® 氣動左右挫磨機 / Pneumatic Swing Lappers



編號 / Order no. :	<b>US-70</b>	<b>US-100</b>
行程 / Stroke :	0.7mm	1.0mm
速度 / Speed :	15,000 spm.	11,000 spm.
重量 / Weight :	190g	190g
尺寸 / Dimensions :	ø28x200mm	ø28x200mm

### US-70, US-100 Swing Air Lappers 左右橫擺氣動銼磨機

- Side to side stroke.
- Special design enable the easiest method of changing the consuming or worn out parts.
- Ideal for filing , lapping and polishing shallow surfaces, deep ribs and parting lines.
- 特殊設計使主要磨耗零件十分容易更換。
- 氣動左右橫擺行程。
- 適合模具淺溝、深肋及公母模接合面等之研磨,防止研磨時工具滑落而傷及模具之銳角。



編號 / Order no. :	<b>US-200</b>
行程 / Stroke :	2.0mm
速度 / Speed :	16,000 spm.
重量 / Weight :	535g
尺寸 / Dimensions :	ø34x205mm

### US-200 Swing Air Lappers 左右橫擺氣動銼磨機

- Side to side stroke.
- Bigger swing stroke suit for lapping bigger surface and excellent for deburring or chamfering works of die casting parts.
- 氣動左右橫擺行程。
- 較大行程，適於較大面積之研磨，並適合各種鑄件或零件之清除毛邊及倒角。

### 附屬工具 / Accessory Tools:

